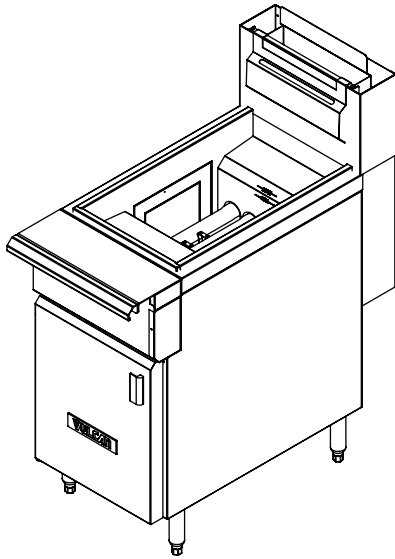

HEAVY DUTY COOKING**VULCAN****HEAVY DUTY GAS RANGE
RANGE MATCH FRYERS****VFRY18****SPECIFICATIONS**

Heavy Duty range match fryers, Vulcan model No. ___VFRY18 (Single Fryer). Fryers with solid state, behind the door controls (120V/60/1), electronic pilot ignition. Four heat exchanger tubes and burners per fryer. Hi-limit shut-off and combination gas shut-off valve. Drain valve interlock switch. Stainless steel front, front top ledge, sides, fry tank (12 year tank warranty), base, and stub back. Units are standard on 6" legs. 1/4" front gas manifold, and 3/4" rear gas connection, capped. 120,000 BTU's/hr. input. Requires 120 volt, 60 Hz, 1 phase power supply. (NEMA 5-15P)

- VFRY18** 18" Single Fryer

STANDARD FEATURES

- Stainless steel front, front top ledge, sides, fry tank, base, and stub back
- 1/4" Diameter front gas manifold
- 3/4" Rear gas connection (capped)
- 120,000 BTU/hr. input
- Four heat exchanger tubes per fryer
- Solid State behind the door controls
- Hi-limit shut off
- Combination gas shut-off valve and pilot ignition system
- Drain valve interlock switch
- Electronic ignition (120 volt/60/1) (NEMA 5-15P)
- Drawn 18 gauge stainless steel filter pan (for filter models)
- Boil Out ByPass™
- 6" adjustable stainless steel legs
- One year limited parts and labor warranty & 5 year limited fry tank warranty

Optional Features (Factory Installed)

- Cap and cover front manifold
- Stainless steel tank cover, doubles as work-top surface
- 10" High Side Splash (removable)
- Flanged Feet
- Set of 4 casters, 6" high (two locking)

ACCESSORIES (Packaged & Sold Separately)

- Extra set of twin Baskets
- Single Bulk Baskets
- Common condiment type, telescoping plate rails (starting at 24" length)
- 10", 22", or 34" high back risers (no shelf)
- 22" single deck solid or flo-thru high shelf risers
- 34" double deck solid or flo-thru high shelf risers
- Flexible gas hose with quick disconnect & restraining device

VULCAN

a division of ITW Food Equipment Group LLC

P.O. Box 696 ■ Louisville, KY 40201 ■ Toll-free: 1-800-814-2028 ■ Local: 502-778-2791 ■ Quote & Order Fax: 1-800-444-0602



HEAVY DUTY GAS RANGE
RANGE MATCH FRYERS

INSTALLATION INSTRUCTIONS

1. A combination valve with pressure regulator is provided with this unit. Natural Gas: 4.0" (102mm) W.C. Propane Gas: 10.0" (254mm) W.C.
2. An adequate ventilation system is required for commercial cooking equipment. Information may be obtained by writing to the National Fire Protection Association, 1 Batterymarch Park, Quincy, MA 02269. When writing refer to NFPA No.96.
3. These units are manufactured for installation in accordance with ANSZ223.1A (latest edition), National Fuel Gas Code. Copies may be obtained from The American Gas Association, 400 N Capitol St., N.W., Washington, DC 20001, www.AGA.org.
4. For proper combustion, install equipment on adjustable legs or casters. On curb or platform, all 3 1/2" front overhang. Toe base with leveling bolts are required for curb installation. Specify when ordering.

5. <u>Clearances</u>	<u>Rear</u>	<u>Sides</u>
Combustible	10"	10"
Noncombustible	0"	0"
Open Top Models	16"	16"

6. Cannot be battered with GH series equipment.
7. This appliance is manufactured for commercial installation only and is not intended for home use.

NOTE: In line with its policy to continually improve its product, Vulcan reserves the right to change materials and specification without notice.

Specify type of gas when ordering.
Specify altitude when above 2,000 feet.

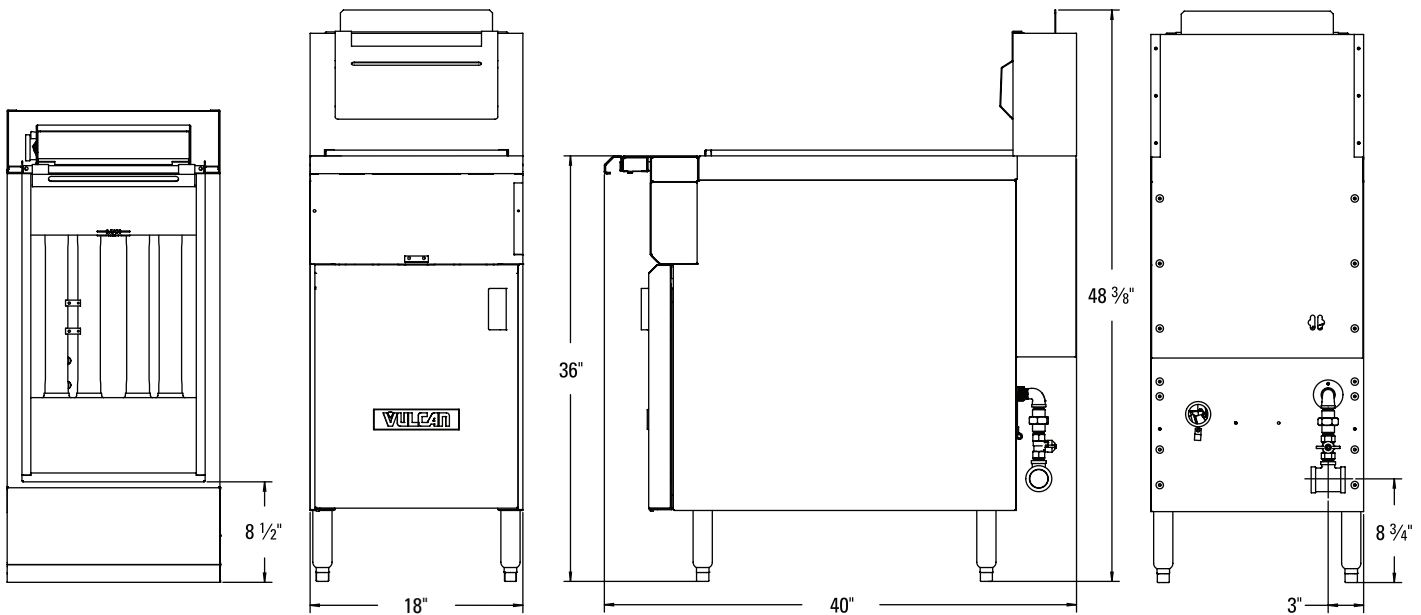

MODEL NUMBER	DESCRIPTION	TOTAL INPUT BTU / HR	SHIPPING WEIGHT LBS / KG
VFRY18	18" Wide, Range Match, Heavy-Duty Fryer.	120,000	215 / 98

This appliance is manufactured for commercial use only and is not intended for home use.



a division of ITW Food Equipment Group LLC

P.O. Box 696 ■ Louisville, KY 40201 ■ Toll-free: 1-800-814-2028 ■ Local: 502-778-2791 ■ Quote & Order Fax: 1-800-444-0602

NOTE: In line with its policy to continually improve its products, Vulcan reserves the right to change materials and specifications without notice.