

COMBITHERM® INSTALLATION

CT PROformance™

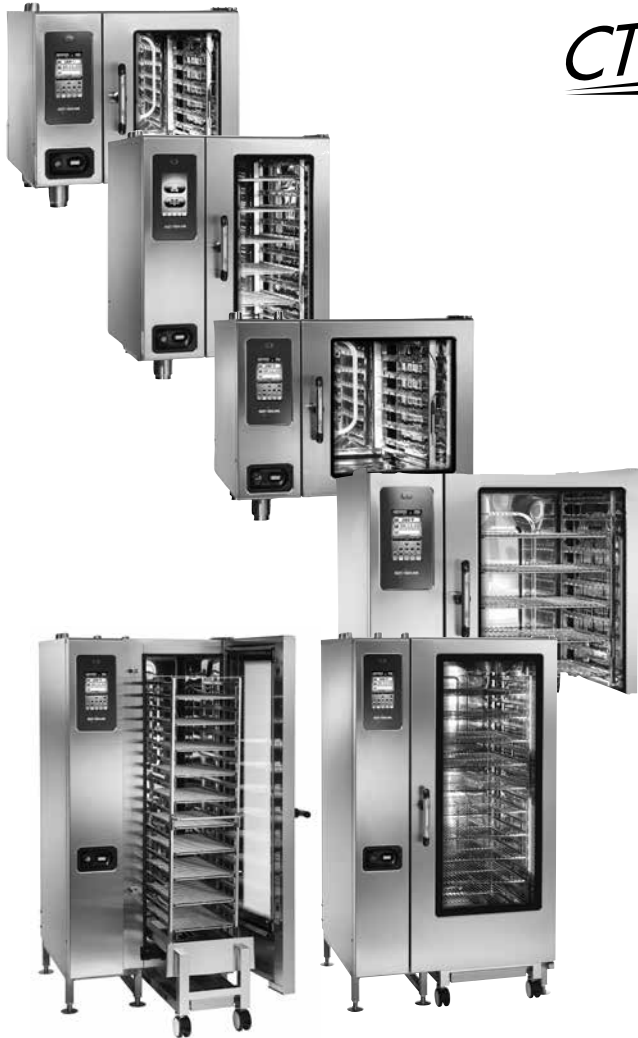

CTP6-10E, CTP6-10G

CTP10-10E, CTP10-10G

CTP7-20E, CTP7-20G

CTP10-20E, CTP10-20G

CTP20-10E, CTP20-10G

CTP20-20E, CTP20-20G

CT Classic™

CTC6-10E, CTC6-10G

CTC10-10E, CTC10-10G

CTC7-20E, CTC7-20G

CTC10-20E, CTC10-20G

CTC20-10E, CTC20-10G

CTC20-20E, CTC20-20G

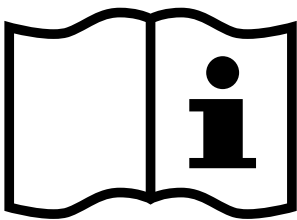

Consult instructions for installation and use.



DANGER



DO NOT store or use gasoline or other flammable vapors or liquids in the vicinity of this or any other appliance.



DANGER

IMPROPER INSTALLATION, ALTERATION, ADJUSTMENT, SERVICE, OR MAINTENANCE COULD RESULT IN SEVERE INJURY, DEATH, OR CAUSE PROPERTY DAMAGE.

READ THE INSTALLATION, OPERATING AND MAINTENANCE INSTRUCTIONS THOROUGHLY BEFORE INSTALLING OR SERVICING THIS EQUIPMENT.

ALTO-SHAAM®

W164 N9221 Water Street • P.O. Box 450 • Menomonee Falls, Wisconsin 53052-0450 • U.S.A.

PHONE: 262.251.3800 800.558.8744 U.S.A./CANADA FAX: 262.251.7067 800.329.8744 U.S.A. ONLY

www.alto-shaam.com



COMBITHERM® INSTALLATION TABLE OF CONTENTS

Delivery.....	1	Stand Installation	34
Unpacking	1	Common Accessories.....	35
Safety Procedures and Precautions.....	2	Electrical Connection for Gas Models	36
Installation		Electrical Connection for Electric Models.....	37
Installation Codes and Standards.....	3	Mobile Equipment Restraint.....	39
Ventilation Requirements	3	Ventilation Requirements	40
Sound Pressure.....	3	Gas Supply & Installation	41
Installation Duties and Responsibilities.....	4	Gas Leak Testing.....	45
Pre-Installation Checklist	6	Gas Exhaust.....	45
Specifications, CTP6-10E.....	9	Water Quality Requirements	47
Specifications, CTC6-10E.....	10	Water Supply & Installation	47
Specifications, CTP6-10G.....	11	Water Drainage.....	48
Specifications, CTC6-10G	12	Combihood PLUS™ Installation	50
Specifications, CTP10-10E.....	13	Grease Collection Hook-up.....	52
Specifications, CTC10-10E.....	14	Liquid Cleaning Hook-up	53
Specifications, CTP10-10G.....	15	CT PROformance Start-up Procedures	54
Specifications, CTC10-10G	16	CT PROformance Screen Calibration	54
Specifications, CTP7-20E	17	CT Classic Start-up Procedures	55
Specifications, CTC7-20E.....	18	Post-Installation Checklist	56
Specifications, CTP7-20G.....	19	Error Codes	58
Specifications, CTC7-20G	20	Service Parts.....	65
Specifications, CTP10-20E.....	21	Warranty	
Specifications, CTC10-20E.....	22	Original Equipment Limited Warranty	66
Specifications, CTP10-20G.....	23	Transportation Damage and Claims.....	67
Specifications, CTC10-20G	24	Please post the following instructions in a prominent location in the event the user smells gas.	
Specifications, CTP20-10E.....	25	DANGER  BEFORE STARTING THE APPLIANCE, MAKE CERTAIN YOU DO NOT DETECT THE ODOR OF GAS. IF THE ODOR OF GAS IS DETECTED: • DO NOT attempt to light any appliance. • DO NOT touch any electrical switches. • Extinguish any open flame. • Use a telephone OUTSIDE THE PROPERTY & IMMEDIATELY contact your gas supplier. • If unable to contact your gas supplier, contact the fire department.	
Specifications, CTC20-10E.....	26		
Specifications, CTP20-10G.....	27		
Specifications, CTC20-10G	28		
Specifications, CTP20-20E.....	29		
Specifications, CTC20-20E.....	30		
Specifications, CTP20-20G.....	31		
Specifications, CTC20-20G	32		
Lifting Instructions.....	33		
Clearance Requirements.....	34		
Positioning on Site	34		



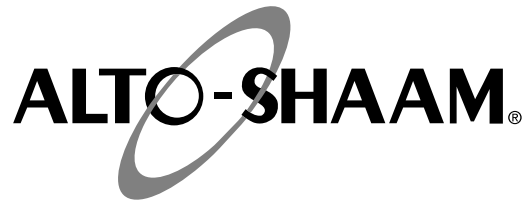

DELIVERY

This Alto-Shaam appliance has been thoroughly tested and inspected to ensure only the highest quality unit is provided. Upon receipt, check for any possible shipping damage and report it at once to the delivering carrier. *See Transportation Damage and Claims section located in this manual.*

This appliance, complete with unattached items and accessories, may have been delivered in one or more packages. Check to ensure that all standard items and options have been received with each model as ordered.

Save all the information and instructions packed with the appliance. Complete and return the warranty card to the factory as soon as possible to ensure prompt service in the event of a warranty parts and labor claim.

This manual must be read and understood by all people using or installing the equipment model. Contact the Alto-Shaam Tech Team Service Department if you have any questions concerning installation, operation, or maintenance.

NOTE: All claims for warranty must include the full model number and serial number of the unit.

UNPACKING

1. Carefully remove the appliance from the carton or crate.

NOTE: Do not discard the carton and other packaging material until you have inspected the unit for hidden damage and tested it for proper operation.

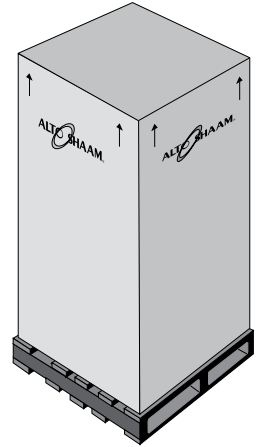

2. Read all instructions in this manual carefully before initiating the installation of this appliance.

DO NOT DISCARD THIS MANUAL.

This manual is considered to be part of the appliance and is to be provided to the owner or manager of the business or to the person responsible for training operators. *Additional manuals are available from the Alto-Shaam Tech Team Service Department.*

3. Remove all protective plastic film, packaging materials, and accessories from the appliance before connecting electrical power. Store any accessories in a convenient place for future use.

CAUTION



**TO PREVENT PERSONAL INJURY,
USE CAUTION WHEN MOVING OR
LEVELING THIS APPLIANCE.**

THE INFORMATION CONTAINED IN THIS MANUAL IS IMPORTANT FOR THE PROPER INSTALLATION OF THIS OVEN. PLEASE READ CAREFULLY AND RETAIN FOR FUTURE REFERENCE.

IMPROPER CONNECTION OF THIS APPLIANCE WILL NULLIFY ALL WARRANTIES.

LES INFORMATIONS CONTENUES DANS CE MANUEL SONT IMPORTANTES POUR UNE INSTALLATION CORRECTE DE CE FOUR. PRIÈRE DE LE LIRE ATTENTIVEMENT ET DE LE CONSERVER POUR POUVOIR S'Y RÉFÉRER À L'AVENIR.

UN BRANCHEMENT INCORRECT DE CET APPAREIL ANNULERA TOUTES LES GARANTIES.

SAFETY PROCEDURES AND PRECAUTIONS

Knowledge of proper procedures is essential to the safe operation of electrically and/or gas energized equipment. In accordance with generally accepted product safety labeling guidelines for potential hazards, the following signal words and symbols may be used throughout this manual.

DANGER	
	Used to indicate the presence of a hazard that WILL cause severe personal injury, death, or substantial property damage if the warning included with this symbol is ignored.

WARNING	
	Used to indicate the presence of a hazard that CAN cause personal injury, possible death, or major property damage if the warning included with this symbol is ignored.

CAUTION	
	Used to indicate the presence of a hazard that can or will cause minor or moderate personal injury or property damage if the warning included with this symbol is ignored.

CAUTION	
Used to indicate the presence of a hazard that can or will cause minor personal injury, property damage, or a potential unsafe practice if the warning included with this symbol is ignored.	

NOTE: Used to notify personnel of installation, operation, or maintenance information that is important but not hazard related.

1. This appliance is intended to cook, hold or process foods for the purpose of human consumption. No other use for this appliance is authorized or recommended.
2. This appliance is intended for use in commercial establishments where all operators are familiar with the purpose, limitations, and associated hazards of this appliance. Operating instructions and warnings must be read and understood by all operators and users.
3. Any troubleshooting guides, component views, and parts lists included in this manual are for general reference only and are intended for use by qualified technical personnel.
4. This manual should be considered a permanent part of this appliance. This manual and all supplied instructions, diagrams, schematics, parts lists, notices, and labels must remain with the appliance if the item is sold or moved to another location.

NOTE	
	For equipment delivered for use in any location regulated by the following directive: DO NOT DISPOSE OF ELECTRICAL OR ELECTRONIC EQUIPMENT WITH OTHER MUNICIPAL WASTE.

CAUTION	
	WHEN WELDING ANY STAINLESS STEEL COMPONENTS ON THIS APPLIANCE, THE ELECTRONIC CONTROL BOARDS MUST BE ISOLATED FROM THE APPLIANCE.

CAUTION	
	CHILDREN MUST BE SUPERVISED AT ALL TIMES WHILE IN THE PRESENCE OF THIS APPLIANCE AND NOT ALLOWED TO PLAY WITH OR OPERATE THE OVEN.

INSTALLATION

SITE INSTALLATION

DANGER



IMPROPER INSTALLATION, ALTERATION, ADJUSTMENT, SERVICE, OR MAINTENANCE COULD RESULT IN SEVERE INJURY, DEATH, OR CAUSE PROPERTY DAMAGE.

READ THE INSTALLATION, OPERATING AND MAINTENANCE INSTRUCTIONS THOROUGHLY BEFORE INSTALLING OR SERVICING THIS EQUIPMENT.

DANGER



AVERTISSEMENT : UNE INSTALLATION, UN AJUSTEMENT, UNE ALTÉRATION, UN SERVICE OU UN ENTRETIEN NON CONFORME AUX NORMES PEUT CAUSER DES DOMMAGES À LA PROPRIÉTÉ, DES BLESSURES OU LA MORT.

LIRE ATTENTIVEMENT LES DIRECTIVES D'OPÉRATION ET D'ENTRETIEN AVANT DE FAIRE L'INSTALLATION, OU L'ENTRETIEN DE CET ÉQUIPEMENT.

INSTALLATION CODES & STANDARDS

The following codes and standards are required for installation of this oven:

AIR SUPPLY, ELECTRICAL CONNECTIONS, WATER CONNECTIONS, AND WASTE WATER DISCHARGE.

Installation must comply with local codes required for gas appliances. In the absence of local codes, installation must comply with the National Fuel Gas Code, ANSI Z223.1 (latest edition). In Canada, the appropriate code is the Natural Gas Installation Code, CAN/CGA-B149.1 or the Propane Installation Code, CAN/CGA-B. Adherence to code by a qualified installer is essential for the following: Gas Plumbing, Gas Appliance Installation, Commercial Cooking Ventilation, Water and Plumbing, and OSHA Regulations and European Standard EN203.

VENTILATION REQUIREMENTS

A steam ventilation hood is mandatory for the operation of the oven. The ventilation hood must be installed in accordance with local building codes for the steam exhaust and must protrude 12-inches to 20-inches (300 to 500mm) over the front side of the oven. A grease filter must be located in the protruding area of the hood. Grease filters should be thoroughly cleaned on a regular basis following manufacturer's instruction. Ventilation hoods must ensure an adequate amount of incoming air during operation and must be operated whenever the combination oven/steamer is used in order to avoid the accumulation of condensation in the hood area.

See the section titled Gas Exhaust.

SOUND PRESSURE MEASUREMENTS

The A-weighted sound pressure level without ventless hood operating is less than 70dBA.



DANGER



DISCONNECT UNIT FROM POWER SOURCE BEFORE CLEANING OR SERVICING.

INSTALLATION DUTIES & RESPONSIBILITIES - NEW CONSTRUCTION

Designer/Consultant Responsibilities: Pre-Installation	
	Complete water analysis to be conducted to ensure water quality meets manufacture specifications.
	Proper floor drain within 6' (1829mm) of where the oven is to be installed.
	Two 3/4" cold water connections with individual shut offs within 3' (914mm) of the oven.
	Gas units require one 3/4" line within 3' (914mm) of the oven equipped with a manual shut off, and ready to be hooked to a 3/4" quick disconnect hose.
	Vent hood, and possible interconnection with gas supply as determined by local code.
	Proper electrical voltage, phase, wire size, breaker size, and disconnects are provided for hook ups
	Exhaust air for gas units, exhaust hood, ventilation ceiling, chimney, spacing from top edge of unit to lower edge of grease filters/ ceiling.
	If floor is to be sloped then level surface must be provided for trolley / cart units.
	Confirm clearances of hallways, and doors to the installation area are sufficient for the model of the oven being installed.
Installer Responsibilities: Pre-Installation	
	Pre-Installation check sheet has been properly filled out.
	Inspect, receive, deliver, uncrate, and set oven in place.
Installer Responsibilities: Installation	
	Check that the oven is level.
	Make final water connections to 3/4" cold water lines with required 30-90 psi (2.1-6.3 bar) making sure treated and un-treated are hooked up properly to the right fittings.
	Hook up final electrical, check for proper voltage, phase, wire size, and breaker size. Do not connect to a G.F.I. outlet. Report any issues to the designer / consultant.
	Plumb in the oven drain per the required specifications found in the installation manual.
	If installing a gas oven hook up final gas connections verifying proper type, and pressure to the unit.
	Check that all accessories are unpackaged and set up for the end user.
	Ensure combi oven is properly fastened to the ground, or has a restraint installed if on castors.
	Test that the CombiOven is fully operational, report any issues or manufacturing defects.
	Insure most current software is installed.
	Pick up any packaging trash and debris from the installation.
	Clean and wipe down the outside of the oven and make presentable to the end user.
	Take pictures of the installation verifying proper drain, water lines, and clearances are met.
ASA Responsibilities: After Install	
	Perform mechanical startup.
	Complete post installation check sheet.
	Pictures of the install's electrical connections, water, drain, and clearances should be taken and sent to: servicedept@alto-shaam.com
RSP/Dealer: After Install	
	Confirm installation is correct.
	Provide operational training and demonstration, and contact information for post installation support.
	Verify warranty registration documentation has been submitted.
Customer/End User	
	Complete and submit warranty registration documentation.
	Use the oven only for its intended purpose.
	Follow cleaning and planned maintenance schedules to maximize the life of the equipment.

INSTALLATION DUTIES & RESPONSIBILITIES - RETRO FIT/EXISTING KITCHEN

Designer/Consultant Responsibilities: <i>Pre-Installation</i>	
	Complete water analysis to be conducted to ensure water quality meets manufacture specifications.
	Proper floor drain within 6' (1829mm) of where the oven is to be installed.
	Two 3/4" cold water connections with individual shut offs within 3' (914mm) of the oven.
	Gas units require one 3/4" line within 3' (914mm) of the oven equipped with a manual shut off, and ready to be hooked to a 3/4" quick disconnect hose.
	Proper vent hood is installed, and possible interconnection with gas supply per by local code.
	Proper electrical voltage, phase, wire size, breaker size, and disconnects are provided for hook ups
	Exhaust air for gas units, exhaust hood, ventilation ceiling, chimney, spacing from top edge of unit to lower edge of grease filters/ ceiling.
	If floor is to be sloped then level surface must be provided for trolley / cart units.
	Confirm clearances of hallways, and doors to the installation area are sufficient for the model of the oven being installed.
Installer Responsibilities: <i>Pre-Installation</i>	
	Pre-Installation check sheet has been properly filled out.
Installer Responsibilities: <i>Installation</i>	
	Inspect, receive, deliver, uncrate, set oven in place, and check that oven is level.
	Make final water connections to 3/4" cold water lines with required 30-90 psi (2.1-6.3 bar) making sure treated and un-treated are hooked up properly to the right fittings.
	Hook up final electrical, check for proper voltage, phase, wire size, and breaker size. Do not connect to a G.F.I. outlet. Report any issues to the designer / consultant.
	Plumb in the oven steam resistant drain per manufactures required specifications as found in the installation manual.
	If installing a gas oven hook up final gas connections verifying proper type, and pressure to the unit.
	Check that all accessories are unpackaged and set up for the end user.
	Ensure combi oven is properly fastened to the ground, or has a restraint installed if on castors.
	Insure most current software is installed / uploaded.
	Verify installation meets the manufacture specifications per the installation manual.
	Test that the CombiOven is fully operational, report any issues or manufacturing defects.
	Pick up any packaging trash and debris from the installation.
	Clean and wipe down the outside of the oven and make presentable to the end user.
	Take pictures of the installation verifying proper drain, water lines, and clearances are met.
ASA Responsibilities: <i>After Install</i>	
	Perform mechanical startup.
	Complete post installation check sheet.
	Pictures of the install's electrical connections, water, drain, and clearances should be taken and sent to: servicedept@alto-shaam.com
RSP/Dealer: <i>After Install</i>	
	Confirm installation is correct.
	Provide operational training and demonstration, and contact information for post installation support.
	Verify warranty registration documentation has been submitted.
Customer/End User	
	Complete and submit warranty registration documentation.
	Use the oven only for its intended purpose.
	Follow cleaning and planned maintenance schedules to maximize the life of the equipment.

COMBITHERM® PRE-INSTALLATION CHECKLIST

Location Name:	<input type="text"/>	Date:	<input type="text"/>
Location Address:	<input type="text"/>	State / Zip Code:	<input type="text"/>
		Building Name:	<input type="text"/>
		Phone:	<input type="text"/>
Contact Name:	<input type="text"/>	E-mail:	<input type="text"/>
Install Company:	<input type="text"/>	Install Technician:	<input type="text"/>
Contact Info:	<input type="text"/>	Number of Combis Being Installed:	<input type="text"/>

	Model Number	Serial Number
❶	<input type="text"/>	<input type="text"/>
❷	<input type="text"/>	<input type="text"/>
❸	<input type="text"/>	<input type="text"/>
❹	<input type="text"/>	<input type="text"/>

Check all clearances of doors, entryways, and hallways from delivery point to installation area.

Measured door/entryway clearance	DOOR 1	<input type="text"/>	DOOR 2	<input type="text"/>	DOOR 3	<input type="text"/>
Measured hallway clearance	HALL 1	<input type="text"/>	HALL 2	<input type="text"/>	HALL 3	<input type="text"/>
Elevator opening	DOOR	<input type="text"/>				
Elevator internal dimensions	HEIGHT	<input type="text"/>	WIDTH	<input type="text"/>	DEPTH	<input type="text"/>

Will ovens fit through all measured locations? YES NO

OVEN UNPACKED DIMENSIONS:

	H	W	D	H	W	D
6-10 Series:	34-1/2"	35-11/16"	41-7/16"	876mm	906mm	1053mm
7-20 Series:	37-13/16"	43-3/4"	46-3/16"	961mm	1111mm	1173mm
10-10 Series:	45-11/16"	35-11/16"	41-7/16"	1160mm	906mm	1053mm
10-20 Series:	45-11/16"	43-3/4"	46-3/16"	1160mm	1111mm	1173mm
20-10 Series:	79-1/4"	35-11/16"	42-1/4"	2012mm	906mm	1072mm
20-20 Series:	79-1/4"	43-3/4"	47"	2012mm	1111mm	1192mm

COMMENTS:

COMBITHERM® PRE-INSTALLATION CHECKLIST CONTINUED

OVEN CLEARANCES:

Right Side:

Back Side:

Left Side:

Bottom:

Top:

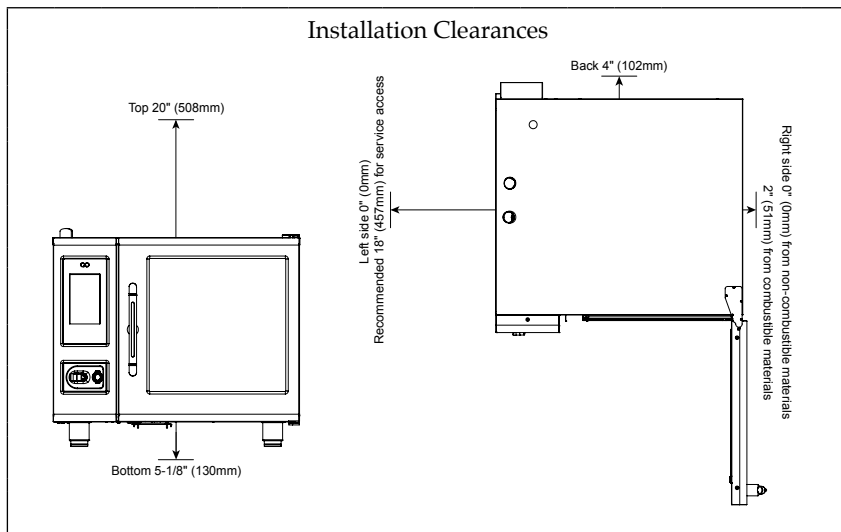

COMMENTS:

WATER SUPPLY:

System needs two (2) 3/4" cold water connections within 3' (914mm) of oven. Water lines can be manifolded off one (1) 3/4" treated water line. Water needs to be between 30 to 90 psi (2.1 – 6.3 bar).

Measured water pressure: PSI BAR

Are there two (2) 3/4" water lines? YES NO

Is at least one (1) line treated water? YES NO

Has a water analysis been complete? YES NO

Does water meet minimum quality standards? YES NO

ELECTRICAL:

Rated oven voltage/phase: Voltage Phase

Actual main voltage provided: Voltage Phase

Actual voltage: L1-N L2-N L3-N

L1-L2 L1-L3 L2-L3

Breaker Size:

COMMENTS:

GAS CONNECTIONS:

Rated gas supply of oven: Nat LP

Actual gas supply available on site: Nat LP

Is a 3/4" hook up available within 3' (914mm) of oven? YES NO

Is a proper ventilation hood installed? YES NO

COMBITHERM® PRE-INSTALLATION CHECKLIST CONTINUED

DRAIN:

Is there a proper floor drain within 6' (1829mm) of the oven?

YES NO

Actual distance to floor drain:

6' (1829mm)

Using the diagram provided, mark the location of the drain.

Draw a simple detail on how the oven's drain line will be routed to the floor drain.

Be sure to use best practices when routing the line to keep it as short as possible.

The drain line should have a positive descending slope. Verify 1/8" (3.2mm) pitch to 10' (305cm) of drain line.

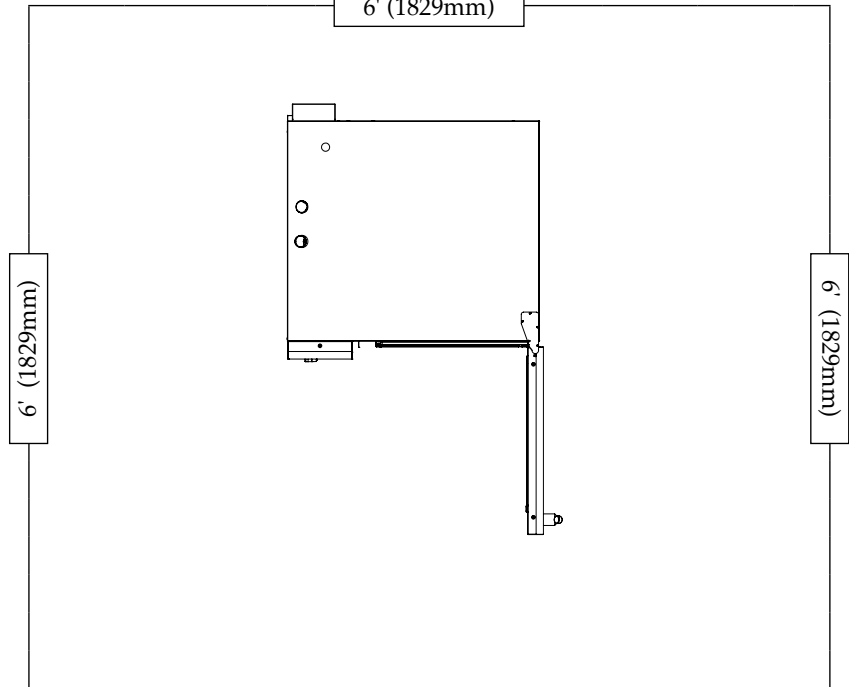

COMMENTS:

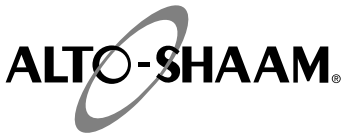

CTP6-10E

**ELECTRIC BOILER-FREE
ELECTRIC BOILER**

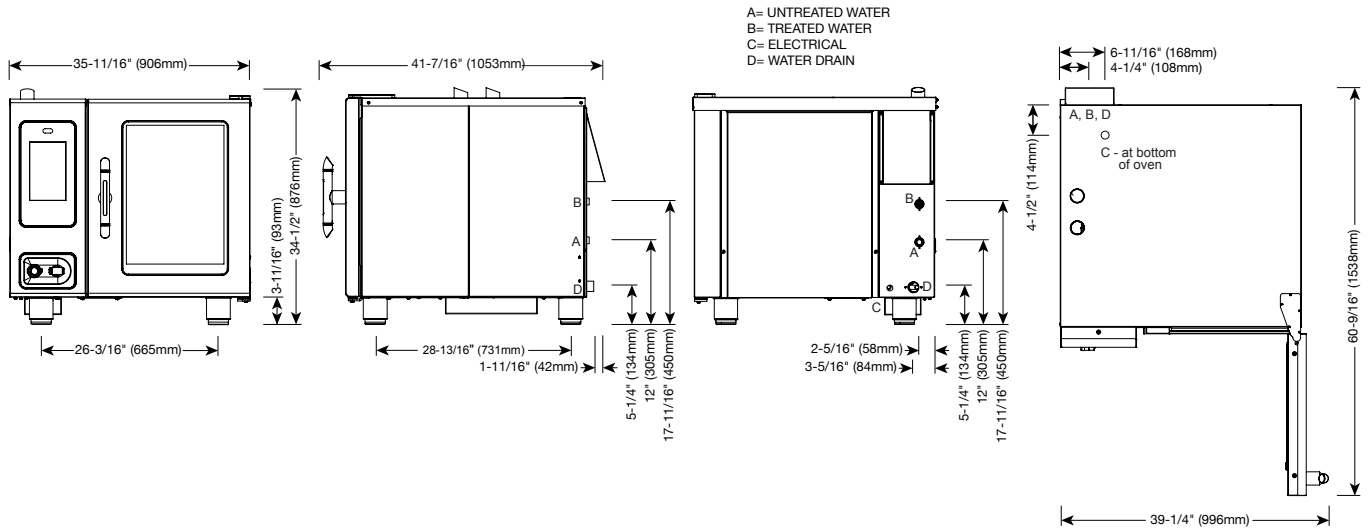

DIMENSIONS: H x W x D

EXTERIOR:

34-1/2" x 35-11/16" x 41-7/16" (876mm x 906mm x 1053mm)

EXTERIOR WITH RECESSED DOOR:

34-1/2" x 39-11/16" x 41-7/16" (876mm x 1008mm x 1053mm)

INTERIOR:

20-1/2" x 16-1/4" x 28-1/16" (520mm x 411mm x 712mm)

WATER REQUIREMENTS

TWO (2) COLD WATER INLETS - DRINKING QUALITY

ONE (1) TREATED WATER INLET: 3/4" NPT* * Can manifold off of one 3/4" line.
ONE (1) UNTREATED WATER INLET: 3/4" NPT*
LINE PRESSURE: 30 to 90 psi 2.1 to 6.3 bar
WATER DRAIN: 1-1/2" (40mm) CONNECTION WITH A 2" MINIMUM AIR GAP INSTALLED AS CLOSE TO THE OVEN AS POSSIBLE. MATERIALS MUST WITHSTAND TEMPERATURES UP TO 200°F (93°C).

CLEARANCE REQUIREMENTS

LEFT: 0" (0mm) 18" (457mm) FOR SERVICE ACCESS
RIGHT: 0" (0mm) NON-COMBUSTIBLE SURFACES 2" (51mm) COMBUSTIBLE SURFACES
TOP: 20" (508mm) FOR AIR MOVEMENT
BACK: 4" (102mm) **BOTTOM:** 5-1/8" (130mm) FOR LEGS, AIR INTAKE

INSTALLATION REQUIREMENTS

- Oven must be installed level.
- Hood installation is required.
- Water supply shut-off valve and back-flow preventer when required by local code.

WATER QUALITY STANDARDS

It is the sole responsibility of the owner/operator/purchaser of this equipment to verify that the incoming water supply is comprehensively tested and if required, a means of "water treatment" provided that would meet compliance requirements with the published water quality standards published below. Non-compliance with these minimum standards will potentially damage this equipment and/or components and VOID the original equipment manufacturer's warranty. Alto-Shaam recommends using OptiPure® [www.optipurewater.com] products to properly treat your water.

Contaminant	Inlet Water Requirements
Free Chlorine	Less than 0.1 ppm (mg/L)
Hardness	30-70 ppm
Chloride	Less than 30 ppm (mg/L)
pH	7.0 to 8.5
Silica	Less than 12 ppm (mg/L)
Total Dissolved Solids (tds)	50-125 ppm

ELECTRICAL - CTP6-10E (NO CORD, NO PLUG, DEDICATED CIRCUIT REQUIRED) DO NOT CONNECT TO A G.F.I. OUTLET

WITH COMBISMOKER® OPTION

					ECO STANDARD			**PROpower™ OPTION			ECO STANDARD			**PROpower™ OPTION		
VOLTAGE	PH	HZ	AWG	CONNECTION	AMPS	KW	BREAKER	AMPS	KW	BREAKER	AMPS	KW	BREAKER	AMPS	KW	BREAKER
208-240	1*	50/60	6	L1, L2/N, G	37.9-43.8	7.9-10.5	40-50	44.2-51.3	9.2-12.3	45-60	40.4-46.6	8.4-11.2	40-50	46.7-54.1	9.7-13	50-60
208-240	3	50/60	8	L1, L2, L3, G	21.9-25.3	7.9-10.5	25-30	28.4-32.6	9.2-12.3	30-35	24.4-28.1	8.4-11.2	25-30	30.9-35.5	9.8-13	35-40
380-415	3	50	8	L1, L2, L3, N, G	13.4-14.6	9-10.5	16	20.3-22.1	10.3-12.3	32	16.1-17.5	9.6-11.2	16-32	22.9-25	10.9-13	32
440-480	3*	60	10-8	L1, L2, L3, G	11.6-12.6	9.1-10.5	15	15-16.7	10.4-12.3	15-20	12.9-14.1	9.6-11.2	15	16.3-18.2	11-13	20

*ELECTRICAL SERVICE CHARGE APPLIES

**NO-COST OPTION ON ELECTRIC MODELS

WEIGHT			SHIP DIMENSIONS		PAN CAPACITY			PRODUCT MAXIMUM:	
NET	524 lbs est	238 kg	(L x W x H)	56" x 45" x 51"	FULL-SIZE:	20" x 12" x 2-1/2"	Six (6)	72 lb (33 kg)	
SHIP	574 lbs*	260 kg*	(1422 x 1143 x 1295mm)*		GN 1/1:	530 x 325 x 65mm	Six (6)	VOLUME MAXIMUM: 45 quarts (57 liters)	
*DOMESTIC GROUND SHIPPING INFORMATION. CONTACT FACTORY FOR EXPORT WEIGHT AND DIMENSIONS.					*HALF-SIZE SHEET: 18" x 13" x 1"			Six (6)	*ADDITIONAL WIRE SHELVES REQUIRED FOR MAXIMUM CAPACITY
					*ON WIRE SHELVES ONLY				

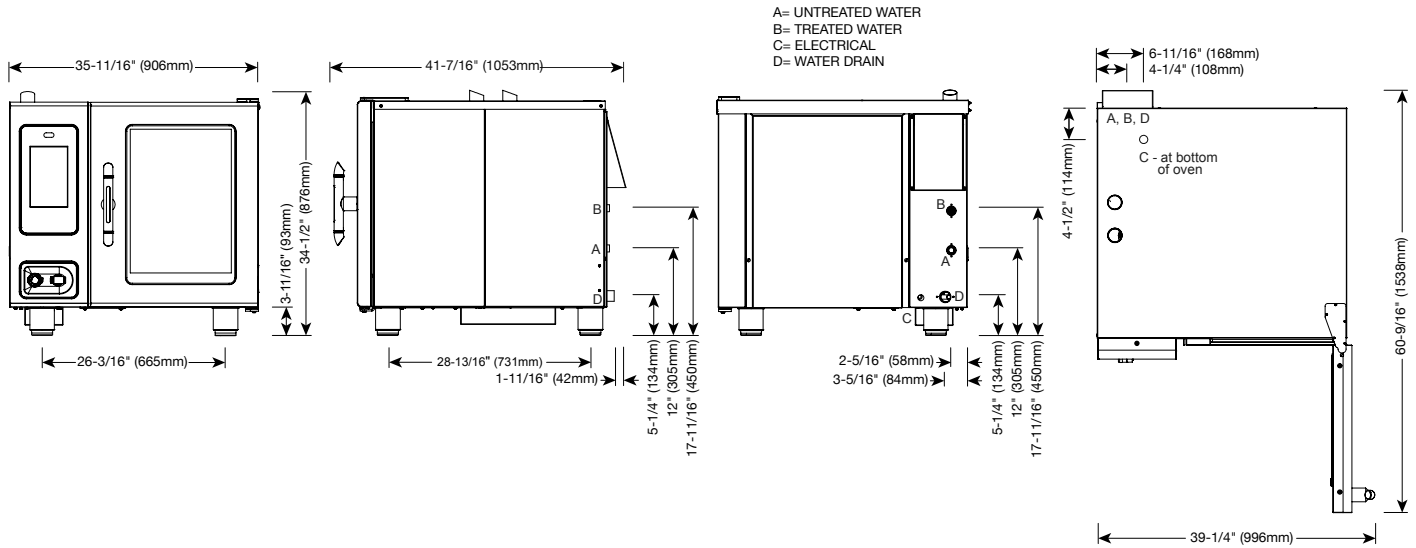

DIMENSIONS: H x W x D
EXTERIOR: 34-1/2" x 35-11/16" x 41-7/16" (876mm x 906mm x 1053mm)
EXTERIOR WITH RECESSED DOOR: 34-1/2" x 39-11/16" x 41-7/16" (876mm x 1008mm x 1053mm)
INTERIOR: 20-1/2" x 16-1/4" x 28-1/16" (520mm x 411mm x 712mm)

WATER REQUIREMENTS	
TWO (2) COLD WATER INLETS - DRINKING QUALITY	
ONE (1) TREATED WATER INLET:	3/4" NPT* * Can manifold off of one 3/4" line.
ONE (1) UNTREATED WATER INLET:	3/4" NPT*
LINE PRESSURE:	30 to 90 psi 2.1 to 6.3 bar
WATER DRAIN: 1-1/2" (40mm) CONNECTION WITH A 2" MINIMUM AIR GAP INSTALLED AS CLOSE TO THE OVEN AS POSSIBLE. MATERIALS MUST WITHSTAND TEMPERATURES UP TO 200°F (93°C).	
CLEARANCE REQUIREMENTS	
LEFT:	0" (0mm) 18" (457mm) FOR SERVICE ACCESS
RIGHT:	0" (0mm) NON-COMBUSTIBLE SURFACES 2" (51mm) COMBUSTIBLE SURFACES
TOP:	20" (508mm) FOR AIR MOVEMENT
BACK:	4" (102mm) BOTTOM: 5-1/8" (130mm) FOR LEGS, AIR INTAKE
INSTALLATION REQUIREMENTS	
• Oven must be installed level. • Hood installation is required.	
• Water supply shut-off valve and back-flow preventer when required by local code.	

WATER QUALITY STANDARDS	
It is the sole responsibility of the owner/operator/purchaser of this equipment to verify that the incoming water supply is comprehensively tested and if required, a means of "water treatment" provided that would meet compliance requirements with the published water quality standards published below. Non-compliance with these minimum standards will potentially damage this equipment and/or components and VOID the original equipment manufacturer's warranty. Alto-Shaam recommends using OptiPure® [www.optipurewater.com] products to properly treat your water.	
Contaminant	Inlet Water Requirements
Free Chlorine	Less than 0.1 ppm (mg/L)
Hardness	30-70 ppm
Chloride	Less than 30 ppm (mg/L)
pH	7.0 to 8.5
Silica	Less than 12 ppm (mg/L)
Total Dissolved Solids (tds)	50-125 ppm

ELECTRICAL (NO CORD, NO PLUG - DEDICATED CIRCUIT REQUIRED) DO NOT CONNECT TO A G.F.I. OUTLET									
MODEL	VOLTAGE	PH	HZ	AMPS	kW	BREAKER	AWG	CONNECTION	
CTC6-10E	208 - 240	3	50/60	21.9 - 25.3	7.9 - 10.5	25 - 30	8	L1, L2, L3, G	
	380 - 415	3	50	13.4 - 14.6	9.0 - 10.5	16	8	L1, L2, L3, N, G	
	440 - 480	3*	60	11.6 - 12.6	9.0 - 10.5	15	10 - 8	L1, L2, L3, G	

*ELECTRICAL SERVICE CHARGE APPLIES

WEIGHT		SHIP DIMENSIONS		PAN CAPACITY			PRODUCT MAXIMUM: 72 lb (33 kg)	
NET	524 lbs est 238 kg	(L x W x H)	56" x 45" x 51"*	FULL-SIZE:	20" x 12" x 2-1/2"	Six (6)	VOLUME MAXIMUM: 45 quarts (57 liters)	
SHIP	574 lbs* 260 kg*	(1422 x 1143 x 1295mm)*		GN 1/1:	530 x 325 x 65mm	Six (6)	*ADDITIONAL WIRE SHELVES REQUIRED FOR MAXIMUM CAPACITY	
*DOMESTIC GROUND SHIPPING INFORMATION. CONTACT FACTORY FOR EXPORT WEIGHT AND DIMENSIONS.				*HALF-SIZE SHEET:	18" x 13" x 1"	Six (6)		
				*ON WIRE SHELVES ONLY				

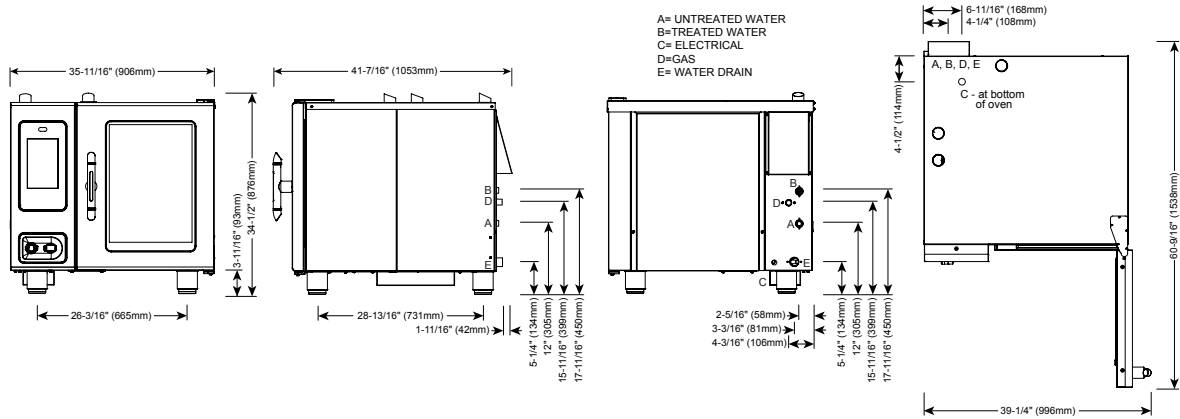

IP X5



DIMENSIONS: H x W x D

EXTERIOR:

34-1/2" x 35-11/16" x 41-7/16" (876mm x 906mm x 1053mm)

EXTERIOR WITH RECESSED DOOR:

34-1/2" x 39-11/16" x 41-7/16" (876mm x 1008mm x 1053mm)

INTERIOR:

20-1/2" x 16-1/4" x 28-1/16" (520mm x 411mm x 712mm)

WATER REQUIREMENTS

TWO (2) COLD WATER INLETS - DRINKING QUALITY

ONE (1) TREATED WATER INLET: 3/4" NPT* * Can manifold off of one
ONE (1) UNTREATED WATER INLET: 3/4" NPT* 3/4" line.
LINE PRESSURE: 30 to 90 psi 2.1 to 6.3 bar
WATER DRAIN: 1-1/2" (40mm) CONNECTION WITH A 2" MINIMUM AIR GAP INSTALLED AS CLOSE TO THE OVEN AS POSSIBLE. MATERIALS MUST WITHSTAND TEMPERATURES UP TO 200°F (93°C).

CLEARANCE REQUIREMENTS

LEFT: 0" (0mm) 18" (457mm) FOR SERVICE ACCESS
RIGHT: 0" (0mm) NON-COMBUSTIBLE SURFACES 2" (51mm) COMBUSTIBLE SURFACES
TOP: 20" (508mm) FOR AIR MOVEMENT
BACK: 4" (102mm) **BOTTOM:** 5-1/8" (130mm) FOR LEGS, AIR INTAKE

INSTALLATION REQUIREMENTS

- Oven must be installed level.
- Hood installation is required.
- Water supply shut-off valve and back-flow preventer when required by local code.

WATER QUALITY STANDARDS

It is the sole responsibility of the owner/operator/purchaser of this equipment to verify that the incoming water supply is comprehensively tested and if required, a means of "water treatment" provided that would meet compliance requirements with the published water quality standards published below. Non-compliance with these minimum standards will potentially damage this equipment and/or components and VOID the original equipment manufacturer's warranty. Alto-Shaam recommends using OptiPure® [www.optipurewater.com] products to properly treat your water.

Contaminant	Inlet Water Requirements
Free Chlorine	Less than 0.1 ppm (mg/L)
Hardness	30-70 ppm
Chloride	Less than 30 ppm (mg/L)
pH	7.0 to 8.5
Silica	Less than 12 ppm (mg/L)
Total Dissolved Solids (tds)	50-125 ppm

GAS REQUIREMENTS (GAS TYPE MUST BE SPECIFIED ON ORDER)

HOOK-UP: 3/4" NPT Alternate burner orifice is required for installation sites at elevations of 2,000 feet (610m) above sea level

RATED THERMAL LOAD

CONNECTED PRESSURE

NORTH AMERICA		INTERNATIONAL		NORTH AMERICA		INTERNATIONAL	
Natural Gas/Propane		G20, G25, G31		Natural Gas	Propane	G20	20mbar
Gross Heating Value (HHV)		Net Heating Value (LHV)		Minimum: 5.5" W.C.	Minimum: 9" W.C.	G25	20mbar
48,000 Btu / hr		13.0 kW		Maximum: 14" W.C.	Maximum: 14" W.C.	G31	30mbar

ELECTRICAL - CTP6-10G (DEDICATED CIRCUIT REQUIRED) DO NOT CONNECT TO A G.F.I. OUTLET

WITH COMBISMOKER® OPTION

	VOLTAGE	PH	HZ	AWG	CONNECTION no cord, no plug	AMPS	BREAKER	kW	CONNECTION no cord, no plug	AMPS	BREAKER	kW
↻	120	1	60	14	L1, N, G	6.8	20	.84	L1, N, G	12.0	20	1.46
↻	208-240	1*	50/60	14	L1, L2/N, G	4.8-4.2	15	1.0	L1, L2/N, G	7.3-7.1	15	1.5-1.7
↻	208-240	3	50/60	14	L1, L2, L3, G	4.8-4.2	15	1.0	L1, L2, L3, G	7.3-7.1	15	1.5-1.7
↻	380-415	3	50	14	L1, L2, L3, N, G	4.6-4.2	15	1.0	L1, L2, L3, N, G	7.2-7.1	15	1.6-1.7

↻ NORTH AMERICA VOLTAGE CHOICE

↻ INTERNATIONAL VOLTAGE CHOICE

*ELECTRICAL SERVICE CHARGE APPLIES

WEIGHT	SHIP DIMENSIONS	PAN CAPACITY	PRODUCT MAXIMUM:
NET 524 lbs est 238 kg	(L x W x H) 56" x 45" x 51"	FULL-SIZE: 20" x 12" x 2-1/2" Six (6)	72 lb (33 kg)
SHIP 574 lbs* 260 kg*	(1422 x 1143 x 1295mm)*	GN 1/1: 530 x 325 x 65mm Six (6)	VOLUME MAXIMUM: 45 quarts (57 liters)
*DOMESTIC GROUND SHIPPING INFORMATION. CONTACT FACTORY FOR EXPORT WEIGHT AND DIMENSIONS.		*HALF-SIZE SHEET: 18" x 13" x 1" Six (6)	*ADDITIONAL WIRE SHELVES REQUIRED FOR MAXIMUM CAPACITY
		*ON WIRE SHELVES ONLY	

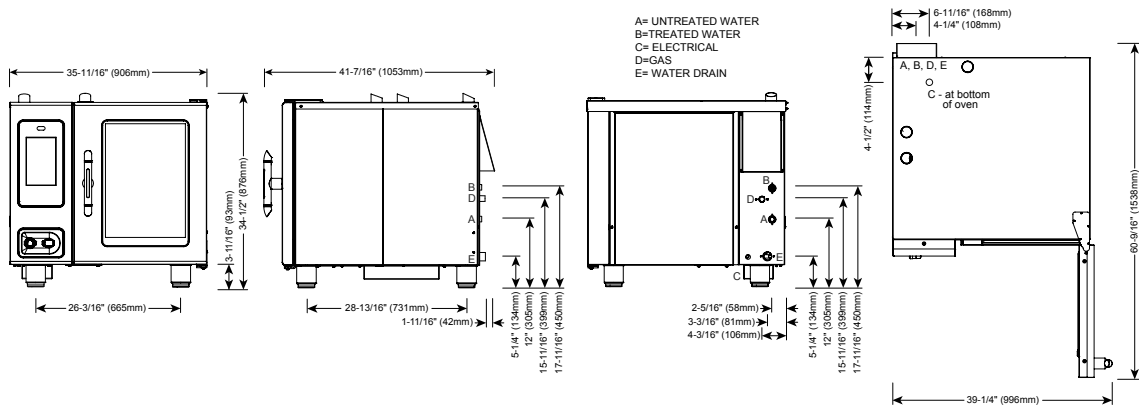

IP X5



DIMENSIONS: H x W x D
EXTERIOR: 34-1/2" x 35-11/16" x 41-7/16" (876mm x 906mm x 1053mm)
EXTERIOR WITH RECESSED DOOR: 34-1/2" x 39-11/16" x 41-7/16" (876mm x 1008mm x 1053mm)
INTERIOR: 20-1/2" x 16-1/4" x 28-1/16" (520mm x 411mm x 712mm)

WATER REQUIREMENTS	
TWO (2) COLD WATER INLETS - DRINKING QUALITY	
ONE (1) TREATED WATER INLET: 3/4" NPT*	* Can manifold off of one 3/4" line.
ONE (1) UNTREATED WATER INLET: 3/4" NPT*	
LINE PRESSURE: 30 to 90 psi	2.1 to 6.3 bar
WATER DRAIN: 1-1/2" (40mm) CONNECTION WITH A 2" MINIMUM AIR GAP INSTALLED AS CLOSE TO THE OVEN AS POSSIBLE. MATERIALS MUST WITHSTAND TEMPERATURES UP TO 200°F (93°C).	
CLEARANCE REQUIREMENTS	
LEFT: 0" (0mm)	18" (457mm) FOR SERVICE ACCESS
RIGHT: 0" (0mm) NON-COMBUSTIBLE SURFACES	2" (51mm) COMBUSTIBLE SURFACES
TOP: 20" (508mm)	FOR AIR MOVEMENT
BACK: 4" (102mm)	BOTTOM: 5-1/8" (130mm) FOR LEGS, AIR INTAKE
INSTALLATION REQUIREMENTS	
• Oven must be installed level. • Hood installation is required.	
• Water supply shut-off valve and back-flow preventer when required by local code.	

WATER QUALITY STANDARDS	
It is the sole responsibility of the owner/operator/purchaser of this equipment to verify that the incoming water supply is comprehensively tested and if required, a means of "water treatment" provided that would meet compliance requirements with the published water quality standards published below. Non-compliance with these minimum standards will potentially damage this equipment and/or components and VOID the original equipment manufacturer's warranty. Alto-Shaam recommends using OptiPure® [www.optipurewater.com] products to properly treat your water.	
Contaminant	Inlet Water Requirements
Free Chlorine	Less than 0.1 ppm (mg/L)
Hardness	30-70 ppm
Chloride	Less than 30 ppm (mg/L)
pH	7.0 to 8.5
Silica	Less than 12 ppm (mg/L)
Total Dissolved Solids (tds)	50-125 ppm

GAS REQUIREMENTS (GAS TYPE MUST BE SPECIFIED ON ORDER)	
HOOK-UP: 3/4" NPT Alternate burner orifice is required for installation sites at elevations of 2,000 feet (610m) above sea level	

RATED THERMAL LOAD		CONNECTED PRESSURE			
NORTH AMERICA	INTERNATIONAL	NORTH AMERICA		INTERNATIONAL	
Natural Gas/Propane	G20, G25, G31	Natural Gas	Propane	G20	20mbar
Gross Heating Value (HHV)	Net Heating Value (LHV)	Minimum: 5.5" W.C.	Minimum: 9" W.C.	G25	20mbar
43,000 Btu / hr	11.5 kW	Maximum: 14" W.C.	Maximum: 14" W.C.	G31	30mbar

ELECTRICAL - CTC6-10G (DEDICATED CIRCUIT REQUIRED) DO NOT CONNECT TO A G.F.I. OUTLET								
	VOLTAGE	PH	HZ	AWG	CONNECTION	AMPS	BREAKER	kW
☞	120	1	60	14	L1, N, G - no cord, no plug	7.0	20	.84
☞	208 - 240	3	50/60	14	L1, L2, L3, G - no cord, no plug	4.8 - 4.2	15	1.0
☛	380 - 415	3	50	14	L1, L2, L3, N, G - no cord, no plug	4.6 - 4.2	15	1.0

☞ NORTH AMERICA VOLTAGE CHOICE ☛ INTERNATIONAL VOLTAGE CHOICE

WEIGHT	SHIP DIMENSIONS	PAN CAPACITY	
NET 524 lbs est 238 kg	(L x W x H) 56" x 45" x 51"*	FULL-SIZE: 20" x 12" x 2-1/2"	Six (6)
SHIP 574 lbs* 260 kg*	(1422 x 1143 x 1295mm)*	GN 1/1: 530 x 325 x 65mm	Six (6)
*DOMESTIC GROUND SHIPPING INFORMATION. CONTACT FACTORY FOR EXPORT WEIGHT AND DIMENSIONS.		*HALF-SIZE SHEET: 18" x 13" x 1"	Six (6)
		*ON WIRE SHELVES ONLY	
		PRODUCT MAXIMUM: 72 lb (33 kg)	
		VOLUME MAXIMUM: 45 quarts (57 liters)	
		*ADDITIONAL WIRE SHELVES REQUIRED FOR MAXIMUM CAPACITY	

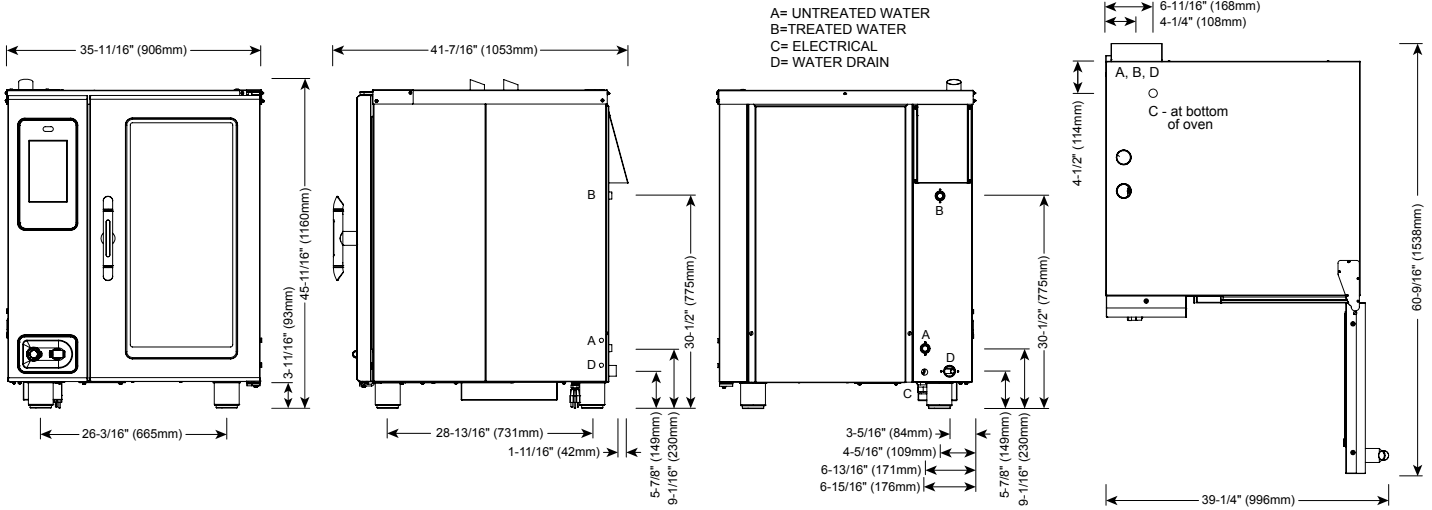

DIMENSIONS: H x W x D

EXTERIOR:

45-11/16" x 35-11/16" x 41-7/16" (1160mm x 906mm x 1053mm)

EXTERIOR WITH RECESSED DOOR:

45-11/16" x 39-11/16" x 41-7/16" (1160mm x 1008mm x 1053mm)

INTERIOR:

31-1/2" x 16-1/4" x 28-1/16" (800mm x 411mm x 712mm)



IP X5



WATER REQUIREMENTS

TWO (2) COLD WATER INLETS - DRINKING QUALITY

ONE (1) TREATED WATER INLET: 3/4" NPT* * Can manifold off of one
ONE (1) UNTREATED WATER INLET: 3/4" NPT* 3/4" line.
LINE PRESSURE: 30 to 90 psi 2.1 to 6.3 bar
WATER DRAIN: 1-1/2" (40mm) CONNECTION WITH A 2" MINIMUM AIR GAP INSTALLED AS CLOSE TO THE OVEN AS POSSIBLE. MATERIALS MUST WITHSTAND TEMPERATURES UP TO 200°F (93°C).

CLEARANCE REQUIREMENTS

LEFT: 0" (0mm) 18" (457mm) FOR SERVICE ACCESS
RIGHT: 0" (0mm) NON-COMBUSTIBLE SURFACES 2" (51mm) COMBUSTIBLE SURFACES
TOP: 20" (508mm) FOR AIR MOVEMENT
BACK: 4" (102mm) **BOTTOM:** 5-1/8" (130mm) FOR LEGS, AIR INTAKE

INSTALLATION REQUIREMENTS

- Oven must be installed level. Hood installation is required.
- Water supply shut-off valve and back-flow preventer when required by local code.

WATER QUALITY STANDARDS

It is the sole responsibility of the owner/operator/purchaser of this equipment to verify that the incoming water supply is comprehensively tested and if required, a means of "water treatment" provided that would meet compliance requirements with the published water quality standards published below. Non-compliance with these minimum standards will potentially damage this equipment and/or components and VOID the original equipment manufacturer's warranty. Alto-Shaam recommends using OptiPure® [www.optipurewater.com] products to properly treat your water.

Contaminant Inlet Water Requirements

Free Chlorine	Less than 0.1 ppm (mg/L)
Hardness	30-70 ppm
Chloride	Less than 30 ppm (mg/L)
pH	7.0 to 8.5
Silica	Less than 12 ppm (mg/L)
Total Dissolved Solids (tds)	50-125 ppm

ELECTRICAL - CTP10-10E (NO CORD, NO PLUG, DEDICATED CIRCUIT REQUIRED) DO NOT CONNECT TO A G.F.I. OUTLET

WITH COMBISMOKER® OPTION

VOLTAGE	PH	HZ	AWG	CONNECTION	ECO STANDARD			**PROpower™ OPTION			ECO STANDARD			**PROpower™ OPTION		
					AMPS	KW	BREAKER	AMPS	KW	BREAKER	AMPS	KW	BREAKER	AMPS	KW	BREAKER
208-240	1*	50/60	2	L1, L2/N, G	68.3-78.8	14.2-18.9	70-80	79.8-92.1	16.6-22.1	80-100	70.8-81.6	14.7-19.6	70-90	82.3-95	17.1-22.8	90-100
208-240	3	50/60	4	L1, L2, L3, G	39.4-45.5	14.2-18.9	40-50	51-58.8	16.6-22.1	60	41.9-48.3	14.7-19.6	50	53.5-61.7	17.1-22.8	60-70
380-415	3	50	6	L1, L2, L3, N, G	24.1-26.3	16.2-18.9	32	36.4-39.6	18.6-22.1	63	26.8-29.1	16.7-19.6	32-63	39-42.5	19.2-22.8	63
440-480	3*	60	8	L1, L2, L3, G	20.8-22.7	16.2-18.9	25	26.9-29.4	18.6-22.1	30	22.2-24.2	16.7-19.6	25	28.3-30.8	19.2-22.8	30

*ELECTRICAL SERVICE CHARGE APPLIES

**NO-COST OPTION ON ELECTRIC MODELS

WEIGHT			SHIP DIMENSIONS		PAN CAPACITY		
NET	625 lbs est	283 kg	(L x W x H) 56" x 45" x 65"	(1422 x 1143 x 1651mm)*	FULL-SIZE:	20" x 12" x 2-1/2"	Ten (10)
SHIP	675 lbs*	306 kg*			GN 1/1:	530 x 325 x 65mm	Ten (10)
*DOMESTIC GROUND SHIPPING INFORMATION. CONTACT FACTORY FOR EXPORT WEIGHT AND DIMENSIONS.					*HALF-SIZE SHEET:	18" x 13" x 1"	Ten (10)
					*ON WIRE SHELVES ONLY		
					PRODUCT MAXIMUM: 120 lb (54 kg)		
					VOLUME MAXIMUM: 75 quarts (95 liters)		
					*ADDITIONAL WIRE SHELVES REQUIRED FOR MAXIMUM CAPACITY		

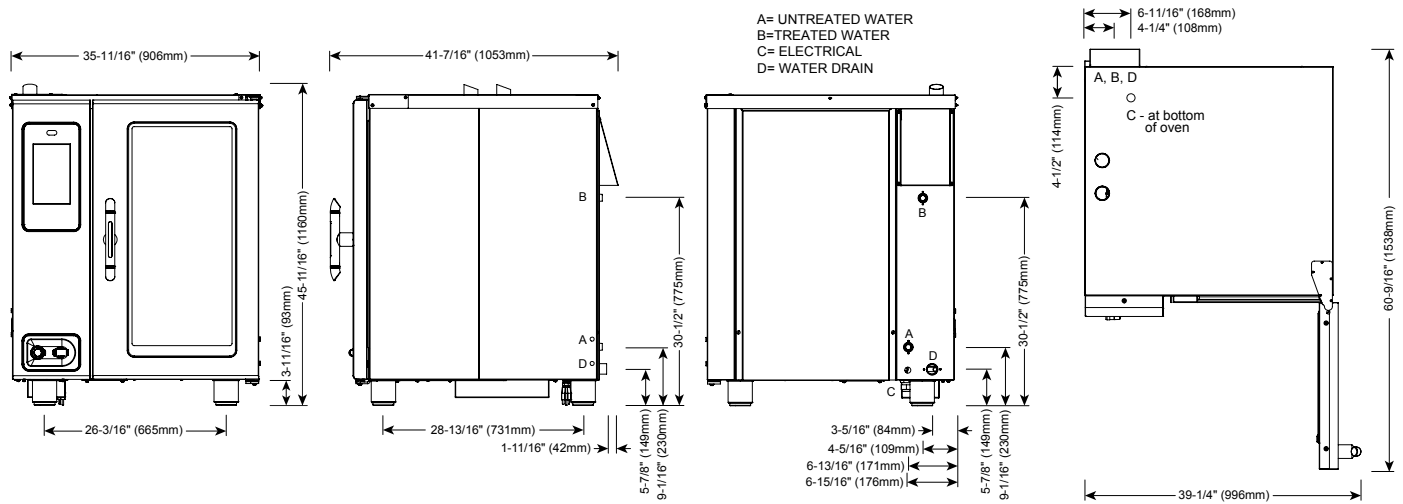

DIMENSIONS: H x W x D
EXTERIOR: 45-11/16" x 35-11/16" x 41-7/16" (1160mm x 906mm x 1053mm)
EXTERIOR WITH RECESSED DOOR: 45-11/16" x 39-11/16" x 41-7/16" (1160mm x 1008mm x 1053mm)
INTERIOR: 31-1/2" x 16-1/4" x 28-1/16" (800mm x 411mm x 712mm)

WATER REQUIREMENTS
TWO (2) COLD WATER INLETS - DRINKING QUALITY
ONE (1) TREATED WATER INLET: 3/4" NPT* * Can manifold off of one
ONE (1) UNTREATED WATER INLET: 3/4" NPT* 3/4" line.
LINE PRESSURE: 30 to 90 psi 2.1 to 6.3 bar
WATER DRAIN: 1-1/2" (40mm) CONNECTION WITH A 2" MINIMUM AIR GAP INSTALLED AS CLOSE TO THE OVEN AS POSSIBLE. MATERIALS MUST WITHSTAND TEMPERATURES UP TO 200°F (93°C).
CLEARANCE REQUIREMENTS
LEFT: 0" (0mm) 18" (457mm) FOR SERVICE ACCESS
RIGHT: 0" (0mm) NON-COMBUSTIBLE SURFACES 2" (51mm) COMBUSTIBLE SURFACES
TOP: 20" (508mm) FOR AIR MOVEMENT
BACK: 4" (102mm) BOTTOM: 5-1/8" (130mm) FOR LEGS, AIR INTAKE
INSTALLATION REQUIREMENTS
• Oven must be installed level. • Hood installation is required.
• Water supply shut-off valve and back-flow preventer when required by local code.

WATER QUALITY STANDARDS
It is the sole responsibility of the owner/operator/purchaser of this equipment to verify that the incoming water supply is comprehensively tested and if required, a means of "water treatment" provided that would meet compliance requirements with the published water quality standards published below. Non-compliance with these minimum standards will potentially damage this equipment and/or components and VOID the original equipment manufacturer's warranty. Alto-Shaam recommends using OptiPure® [www.optipurewater.com] products to properly treat your water.
Contaminant Inlet Water Requirements
Free Chlorine Less than 0.1 ppm (mg/L)
Hardness 30-70 ppm
Chloride Less than 30 ppm (mg/L)
pH 7.0 to 8.5
Silica Less than 12 ppm (mg/L)
Total Dissolved Solids (tds) 50-125 ppm

ELECTRICAL (NO CORD, NO PLUG, DEDICATED CIRCUIT REQUIRED) DO NOT CONNECT TO A G.F.I. OUTLET								
MODEL	VOLTAGE	PH	HZ	AMPS	KW	BREAKER	AWG	CONNECTION
CTC10-10E	208 - 240	3	50/60	39.4 - 45.5	14.2 - 18.9	40-50	4	L1, L2, L3, G
	380 - 415	3	50	24.1 - 26.2	16.2 - 18.9	32	6	L1, L2, L3, N, G
	440 - 480	3*	60	20.8 - 22.7	16.2 - 18.9	25	8	L1, L2, L3, G

*ELECTRICAL SERVICE CHARGE APPLIES

WEIGHT	SHIP DIMENSIONS	PAN CAPACITY	
NET 625 lbs est 283 kg	(L x W x H) 56" x 45" x 65"*	FULL-SIZE: 20" x 12" x 2-1/2"	Ten (10)
SHIP 675 lbs* 306 kg*	(1422 x 1143 x 1651mm)*	GN 1/1: 530 x 325 x 65mm	Ten (10)
*DOMESTIC GROUND SHIPPING INFORMATION. CONTACT FACTORY FOR EXPORT WEIGHT AND DIMENSIONS.		*HALF-SIZE SHEET: 18" x 13" x 1"	Ten (10)
		*ON WIRE SHELVES ONLY	
		PRODUCT MAXIMUM: 120 lb (54 kg)	
		VOLUME MAXIMUM: 75 quarts (95 liters)	
		*ADDITIONAL WIRE SHELVES REQUIRED FOR MAXIMUM CAPACITY	

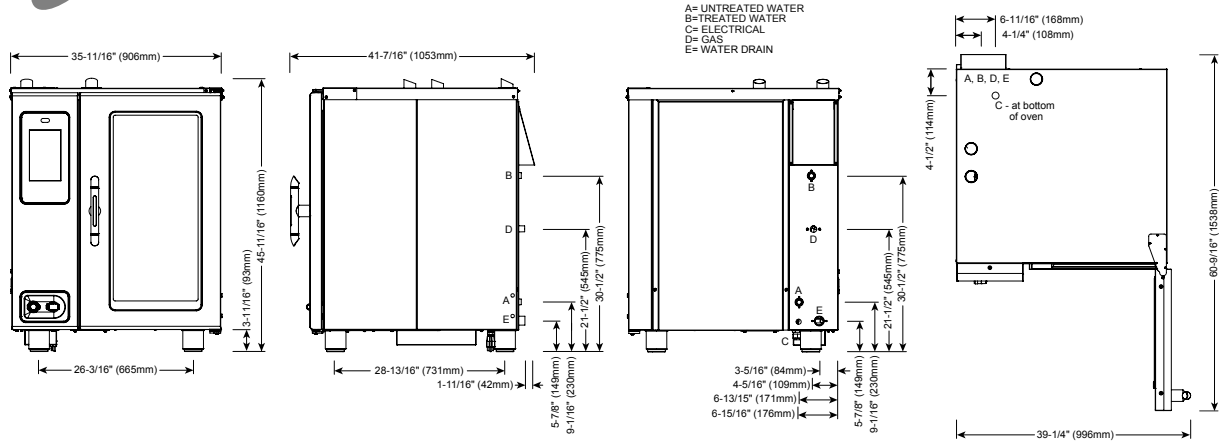

DIMENSIONS: H x W x D
EXTERIOR: 45-11/16" x 35-11/16" x 41-7/16" (1160mm x 906mm x 1053mm)
EXTERIOR WITH RECESSED DOOR: 45-11/16" x 39-11/16" x 41-7/16" (1160mm x 1008mm x 1053mm)
INTERIOR: 31-1/2" x 16-1/4" x 28-1/16" (800mm x 411mm x 712mm)

WATER REQUIREMENTS
TWO (2) COLD WATER INLETS - DRINKING QUALITY
ONE (1) TREATED WATER INLET: 3/4" NPT* * Can manifold off of one
ONE (1) UNTREATED WATER INLET: 3/4" NPT* 3/4" line.
LINE PRESSURE: 30 to 90 psi 2.1 to 6.3 bar
WATER DRAIN: 1-1/2" (40mm) CONNECTION WITH A 2" MINIMUM AIR GAP INSTALLED AS CLOSE TO THE OVEN AS POSSIBLE. MATERIALS MUST WITHSTAND TEMPERATURES UP TO 200°F (93°C).

WATER QUALITY STANDARDS
It is the sole responsibility of the owner/operator/purchaser of this equipment to verify that the incoming water supply is comprehensively tested and if required, a means of "water treatment" provided that would meet compliance requirements with the published water quality standards published below. Non-compliance with these minimum standards will potentially damage this equipment and/or components and VOID the original equipment manufacturer's warranty. Alto-Shaam recommends using OptiPure® [www.optipurewater.com] products to properly treat your water.

CLEARANCE REQUIREMENTS
LEFT: 0" (0mm) 18" (457mm) FOR SERVICE ACCESS
RIGHT: 0" (0mm) NON-COMBUSTIBLE SURFACES 2" (51mm) COMBUSTIBLE SURFACES
TOP: 20" (508mm) FOR AIR MOVEMENT
BACK: 4" (102mm) BOTTOM: 5-1/8" (130mm) FOR LEGS, AIR INTAKE

Contaminant	Inlet Water Requirements
Free Chlorine	Less than 0.1 ppm (mg/L)
Hardness	30-70 ppm
Chloride	Less than 30 ppm (mg/L)
pH	7.0 to 8.5
Silica	Less than 12 ppm (mg/L)
Total Dissolved Solids (tds)	50-125 ppm

INSTALLATION REQUIREMENTS
• Oven must be installed level. • Hood installation is required.
• Water supply shut-off valve and back-flow preventer when required by local code.

GAS REQUIREMENTS (GAS TYPE MUST BE SPECIFIED ON ORDER)					
HOOK-UP: 3/4" NPT Alternate burner orifice is required for installation sites at elevations of 2,000 feet (610m) above sea level					
RATED THERMAL LOAD			CONNECTED PRESSURE		
NORTH AMERICA	INTERNATIONAL		NORTH AMERICA		INTERNATIONAL
Natural Gas/Propane	G20, G25, G31		Natural Gas	Propane	G20 20mbar
Gross Heating Value (HHV)	Net Heating Value (LHV)		Minimum: 5.5" W.C.	Minimum: 9" W.C.	G25 20mbar
80,000 Btu / hr	21.0 kW		Maximum: 14" W.C.	Maximum: 14" W.C.	G31 30mbar

ELECTRICAL - CTP10-10G (DEDICATED CIRCUIT REQUIRED) DO NOT CONNECT TO A G.F.I. OUTLET									WITH COMBISMOKER® OPTION			
	VOLTAGE	PH	HZ	AWG	CONNECTION no cord, no plug	AMPS	BREAKER	kW	CONNECTION no cord, no plug	AMPS	BREAKER	kW
☞	120	1	60	14	L1, N, G	6.8	20	.84	L1, N, G	12.0	20	1.46
☛	208 - 240	1*	50/60	14	L1, L2/N, G	4.8 - 4.2	15	1.0	L1, L2/N, G	7.3 - 7.1	15	1.5 - 1.7
☞	208 - 240	3	50/60	14	L1, L2, L3, G	4.8 - 4.2	15	1.0	L1, L2, L3, G	7.3 - 7.1	15	1.5 - 1.7
☛	380 - 415	3	50	14	L1, L2, L3, N, G	4.6 - 4.2	15	1.0	L1, L2, L3, N, G	7.2 - 7.1	15	1.6 - 1.7

☞ NORTH AMERICA VOLTAGE CHOICE			☛ INTERNATIONAL VOLTAGE CHOICE			*ELECTRICAL SERVICE CHARGE APPLIES			
WEIGHT	SHIP DIMENSIONS		PAN CAPACITY						
NET 625 lbs est 283 kg	(L x W x H) 56" x 45" x 65"		FULL-SIZE:	20" x 12" x 2-1/2"	Ten (10)	PRODUCT MAXIMUM: 120 lb (54 kg)			
SHIP 675 lbs* 306 kg*	(1422 x 1143 x 1651mm)*		GN 1/1:	530 x 325 x 65mm	Ten (10)	VOLUME MAXIMUM: 75 quarts (95 liters)			
*DOMESTIC GROUND SHIPPING INFORMATION. CONTACT FACTORY FOR EXPORT WEIGHT AND DIMENSIONS.			*HALF-SIZE SHEET:	18" x 13" x 1"	Ten (10)	*ADDITIONAL WIRE SHELVES REQUIRED FOR MAXIMUM CAPACITY			
			*ON WIRE SHELVES ONLY						

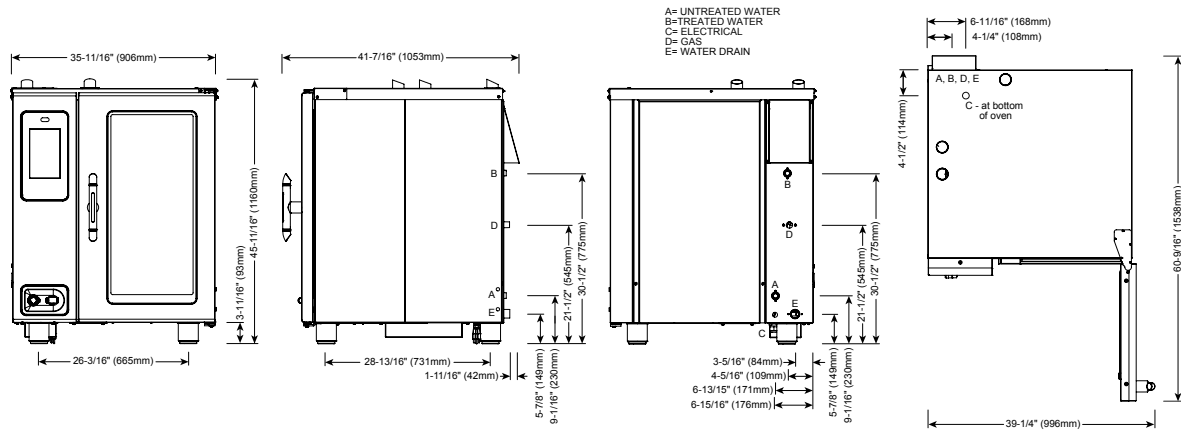

IP X5



DIMENSIONS: H x W x D

EXTERIOR:

45-11/16" x 35-11/16" x 41-7/16" (1160mm x 906mm x 1053mm)

EXTERIOR WITH RECESSED DOOR:

45-11/16" x 39-11/16" x 41-7/16" (1160mm x 1008mm x 1053mm)

INTERIOR:

31-1/2" x 16-1/4" x 28-1/16" (800mm x 411mm x 712mm)

WATER REQUIREMENTS

TWO (2) COLD WATER INLETS - DRINKING QUALITY

ONE (1) TREATED WATER INLET: 3/4" NPT* * Can manifold off of one

ONE (1) UNTREATED WATER INLET: 3/4" NPT* 3/4" line.

LINE PRESSURE: 30 to 90 psi 2.1 to 6.3 bar

WATER DRAIN: 1-1/2" (40mm) CONNECTION WITH A 2" MINIMUM AIR GAP INSTALLED AS CLOSE TO THE OVEN AS POSSIBLE. MATERIALS MUST WITHSTAND TEMPERATURES UP TO 200°F (93°C).

CLEARANCE REQUIREMENTS

LEFT: 0" (0mm) 18" (457mm) FOR SERVICE ACCESS

RIGHT: 0" (0mm) NON-COMBUSTIBLE SURFACES 2" (51mm) COMBUSTIBLE SURFACES

TOP: 20" (508mm) FOR AIR MOVEMENT

BACK: 4" (102mm) **BOTTOM:** 5-1/8" (130mm) FOR LEGS, AIR INTAKE

INSTALLATION REQUIREMENTS

- Oven must be installed level. • Hood installation is required.
- Water supply shut-off valve and back-flow preventer when required by local code.

WATER QUALITY STANDARDS

It is the sole responsibility of the owner/operator/purchaser of this equipment to verify that the incoming water supply is comprehensively tested and if required, a means of "water treatment" provided that would meet compliance requirements with the published water quality standards published below. Non-compliance with these minimum standards will potentially damage this equipment and/or components and VOID the original equipment manufacturer's warranty. Alto-Shaam recommends using OptiPure® [www.optipurewater.com] products to properly treat your water.

Contaminant Inlet Water Requirements

Free Chlorine	Less than 0.1 ppm (mg/L)
Hardness	30-70 ppm
Chloride	Less than 30 ppm (mg/L)
pH	7.0 to 8.5
Silica	Less than 12 ppm (mg/L)
Total Dissolved Solids (tds)	50-125 ppm

GAS REQUIREMENTS (GAS TYPE MUST BE SPECIFIED ON ORDER)

HOOK-UP: 3/4" NPT Alternate burner orifice is required for installation sites at elevations of 2,000 feet (610m) above sea level

RATED THERMAL LOAD		CONNECTED PRESSURE			
NORTH AMERICA	INTERNATIONAL	NORTH AMERICA		INTERNATIONAL	
Natural Gas/Propane	G20, G25, G31	Natural Gas	Propane	G20	20mbar
Gross Heating Value (HHV)	Net Heating Value (LHV)	Minimum: 5.5" W.C.	Minimum: 9" W.C.	G25	20mbar
70,000 Btu / hr	18.5 kW	Maximum: 14" W.C.	Maximum: 14" W.C.	G31	30mbar

ELECTRICAL - CTC10-10G (DEDICATED CIRCUIT REQUIRED) DO NOT CONNECT TO A G.F.I. OUTLET

	VOLTAGE	PH	HZ	AWG	CONNECTION	AMPS	BREAKER	KW
↻	120	1	60	14	L1, N, G - no cord, no plug	7	20	.84
↻	208 - 240	3	50/60	14	L1, L2, L3, G - no cord, no plug	4.8 - 4.2	15	1.0
↻	380 - 415	3	50	14	L1, L2, L3, N, G - no cord, no plug	4.6 - 4.2	15	1.0

↻ NORTH AMERICA VOLTAGE CHOICE

↻ INTERNATIONAL VOLTAGE CHOICE

WEIGHT	SHIP DIMENSIONS	PAN CAPACITY		PRODUCT MAXIMUM:
NET 625 lbs est 283 kg	(L x W x H) 56" x 45" x 65"	FULL-SIZE:	20" x 12" x 2-1/2"	120 lb (54 kg)
SHIP 675 lbs* 306 kg*	(1422 x 1143 x 1651mm)*	GN 1/1:	530 x 325 x 65mm	VOLUME MAXIMUM: 75 quarts (95 liters)
*DOMESTIC GROUND SHIPPING INFORMATION. CONTACT FACTORY FOR EXPORT WEIGHT AND DIMENSIONS.		*HALF-SIZE SHEET:	18" x 13" x 1"	*ADDITIONAL WIRE SHELVES REQUIRED FOR MAXIMUM CAPACITY
		*ON WIRE SHELVES ONLY		

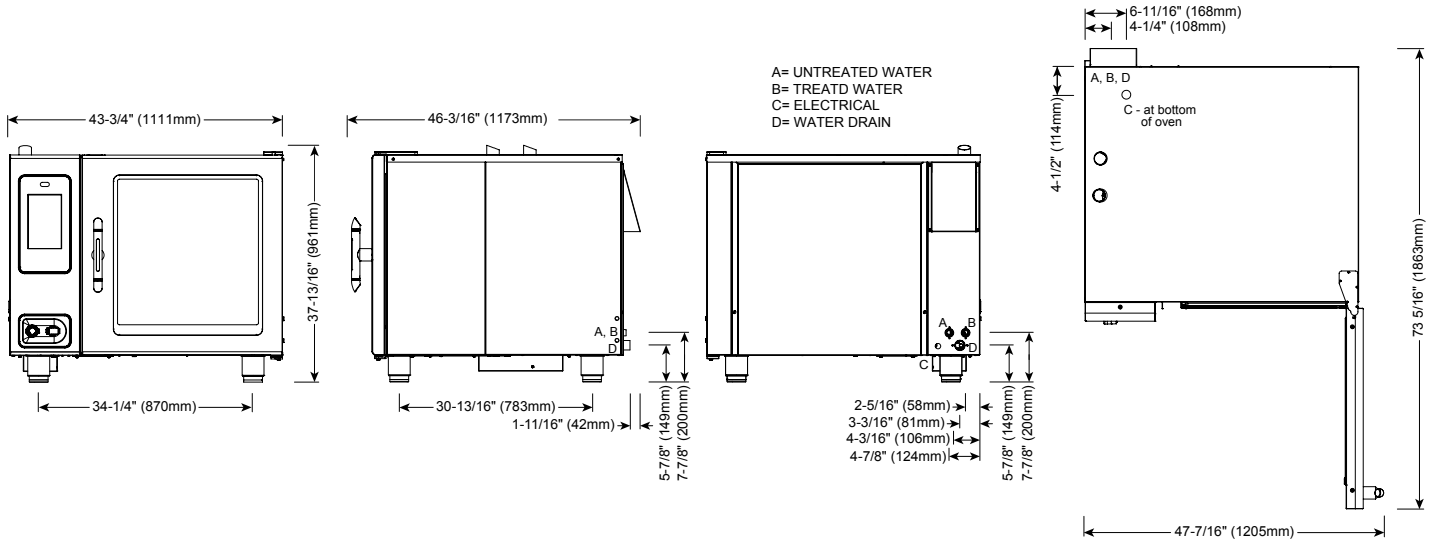

DIMENSIONS: H x W x D
EXTERIOR: 37-13/16" x 43-3/4" x 46-3/16" (961mm x 1111mm x 1173mm)
EXTERIOR WITH RECESSED DOOR: 37-13/16" x 47-3/4" x 46-3/16" (961mm x 1213mm x 1173mm)
INTERIOR: 23-1/4" x 24-1/4" x 32-3/4" (590mm x 616mm x 832mm)



WATER REQUIREMENTS
TWO (2) COLD WATER INLETS - DRINKING QUALITY
ONE (1) TREATED WATER INLET: 3/4" NPT* * Can manifold off of one 3/4" line.
ONE (1) UNTREATED WATER INLET: 3/4" NPT*
LINE PRESSURE: 30 to 90 psi 2.1 to 6.3 bar
WATER DRAIN: 1-1/2" (40mm) CONNECTION WITH A 2" MINIMUM AIR GAP INSTALLED AS CLOSE TO THE OVEN AS POSSIBLE. MATERIALS MUST WITHSTAND TEMPERATURES UP TO 200°F (93°C).
CLEARANCE REQUIREMENTS
LEFT: 0" (0mm) 18" (457mm) FOR SERVICE ACCESS
RIGHT: 0" (0mm) NON-COMBUSTIBLE SURFACES 2" (51mm) COMBUSTIBLE SURFACES
TOP: 20" (508mm) FOR AIR MOVEMENT
BACK: 4" (102mm) BOTTOM: 5-1/8" (130mm) FOR LEGS, AIR INTAKE
INSTALLATION REQUIREMENTS
• Oven must be installed level. • Hood installation is required.
• Water supply shut-off valve and back-flow preventer when required by local code.

WATER QUALITY STANDARDS
It is the sole responsibility of the owner/operator/purchaser of this equipment to verify that the incoming water supply is comprehensively tested and if required, a means of "water treatment" provided that would meet compliance requirements with the published water quality standards published below. Non-compliance with these minimum standards will potentially damage this equipment and/or components and VOID the original equipment manufacturer's warranty. Alto-Shaam recommends using OptiPure® [www.optipurewater.com] products to properly treat your water.
Contaminant Inlet Water Requirements
Free Chlorine Less than 0.1 ppm (mg/L)
Hardness 30-70 ppm
Chloride Less than 30 ppm (mg/L)
pH 7.0 to 8.5
Silica Less than 12 ppm (mg/L)
Total Dissolved Solids (tds) 50-125 ppm

ELECTRICAL - CTP7-20E (NO CORD, NO PLUG, DEDICATED CIRCUIT REQUIRED) DO NOT CONNECT TO A G.F.I. OUTLET										WITH COMBISMOKER® OPTION						
					ECO STANDARD			**PROpower™ OPTION			ECO STANDARD			**PROpower™ OPTION		
VOLTAGE	PH	HZ	AWG	CONNECTION	AMPS	KW	BREAKER	AMPS	KW	BREAKER	AMPS	KW	BREAKER	AMPS	KW	BREAKER
208 - 240	1*	50/60	1 - 1/0	L1, L2/N, G	79.1 - 91.3	16.5 - 21.9	80 - 100	92.1 - 106.3	19.2 - 25.5	100 - 110	81.6 - 94.1	17 - 22.6	90 - 100	94.6 - 109.1	19.7 - 26.2	100 - 110
208 - 240	3	50/60	4 - 3	L1, L2, L3, G	45.7 - 52.7	16.5 - 21.9	50 - 60	58.7 - 67.7	19.2 - 25.5	60 - 70	48.2 - 55.6	17 - 22.6	50 - 60	61.2 - 70.6	19.7 - 26.2	70
380 - 415	3	50	6 - 4	L1, L2, L3, N, G	28 - 30.4	18.7 - 21.9	32	41.7 - 45.4	21.4 - 25.5	63	30.6 - 33.3	19.3 - 22.6	32 - 63	44.4 - 48.3	22 - 26.2	63
440 - 480	3*	60	8	L1, L2, L3, G	24.1 - 26.3	18.8 - 21.9	25 - 30	31 - 33.8	21.5 - 25.5	35	25.5 - 27.8	19.3 - 22.6	30	32.3 - 35.3	22.1 - 26.2	35

*ELECTRICAL SERVICE CHARGE APPLIES

**NO-COST OPTION ON ELECTRIC MODELS

WEIGHT	SHIP DIMENSIONS	PAN CAPACITY	
NET 680 lbs est 308 kg	(L x W x H) 56" x 48" x 1**	FULL-SIZE: 20" x 12" x 2-1/2"	Fourteen (14)
SHIP 720 lbs* 327 kg*	(1422 x 1219 x 1295mm)*	*ON WIRE GN 1/1: 530 x 325 x 65mm	Fourteen (14)
		*ON WIRE GN 2/1: 650 x 530 x 65mm	Seven (7)
		*FULL-SIZE SHEET: 18" x 26" x 1"	Seven (7)
			PRODUCT MAXIMUM: 168 lb (76 kg)
			VOLUME MAXIMUM: 105 quarts (133 liters)
			*ADDITIONAL WIRE SHELVES REQUIRED FOR MAXIMUM CAPACITY

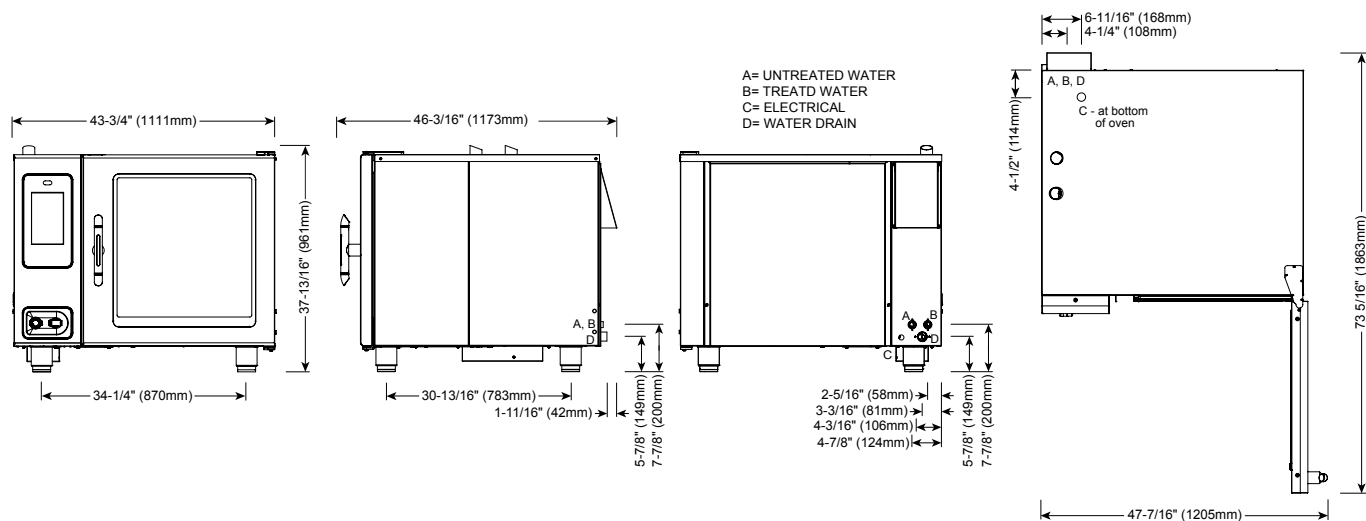

DIMENSIONS: H x W x D
EXTERIOR: 37-13/16" x 43-3/4" x 46-3/16" (961mm x 1111mm x 1173mm)
EXTERIOR WITH RECESSED DOOR: 37-13/16" x 47-3/4" x 46-3/16" (961mm x 1213mm x 1173mm)
INTERIOR: 23-1/4" x 24-1/4" x 32-3/4" (590mm x 616mm x 832mm)

WATER REQUIREMENTS	WATER QUALITY STANDARDS														
<p>TWO (2) COLD WATER INLETS - DRINKING QUALITY</p> <p>ONE (1) TREATED WATER INLET: 3/4" NPT* * Can manifold off of one 3/4" line.</p> <p>ONE (1) UNTREATED WATER INLET: 3/4" NPT*</p> <p>LINE PRESSURE: 30 to 90 psi 2.1 to 6.3 bar</p> <p>WATER DRAIN: 1-1/2" (40mm) CONNECTION WITH A 2" MINIMUM AIR GAP INSTALLED AS CLOSE TO THE OVEN AS POSSIBLE. MATERIALS MUST WITHSTAND TEMPERATURES UP TO 200°F (93°C).</p>	<p>It is the sole responsibility of the owner/operator/purchaser of this equipment to verify that the incoming water supply is comprehensively tested and if required, a means of "water treatment" provided that would meet compliance requirements with the published water quality standards published below. Non-compliance with these minimum standards will potentially damage this equipment and/or components and VOID the original equipment manufacturer's warranty. Alto-Shaam recommends using OptiPure® [www.optipurewater.com] products to properly treat your water.</p> <table border="1"> <thead> <tr> <th>Contaminant</th> <th>Inlet Water Requirements</th> </tr> </thead> <tbody> <tr> <td>Free Chlorine</td> <td>Less than 0.1 ppm (mg/L)</td> </tr> <tr> <td>Hardness</td> <td>30-70 ppm</td> </tr> <tr> <td>Chloride</td> <td>Less than 30 ppm (mg/L)</td> </tr> <tr> <td>pH</td> <td>7.0 to 8.5</td> </tr> <tr> <td>Silica</td> <td>Less than 12 ppm (mg/L)</td> </tr> <tr> <td>Total Dissolved Solids (tds)</td> <td>50-125 ppm</td> </tr> </tbody> </table>	Contaminant	Inlet Water Requirements	Free Chlorine	Less than 0.1 ppm (mg/L)	Hardness	30-70 ppm	Chloride	Less than 30 ppm (mg/L)	pH	7.0 to 8.5	Silica	Less than 12 ppm (mg/L)	Total Dissolved Solids (tds)	50-125 ppm
Contaminant		Inlet Water Requirements													
Free Chlorine		Less than 0.1 ppm (mg/L)													
Hardness		30-70 ppm													
Chloride		Less than 30 ppm (mg/L)													
pH	7.0 to 8.5														
Silica	Less than 12 ppm (mg/L)														
Total Dissolved Solids (tds)	50-125 ppm														
CLEARANCE REQUIREMENTS															
LEFT: 0" (0mm) 18" (457mm) FOR SERVICE ACCESS															
RIGHT: 0" (0mm) NON-COMBUSTIBLE SURFACES 2" (51mm) COMBUSTIBLE SURFACES															
TOP: 20" (508mm) FOR AIR MOVEMENT															
BACK: 4" (102mm) BOTTOM: 5-1/8" (130mm) FOR LEGS, AIR INTAKE															
INSTALLATION REQUIREMENTS															
<ul style="list-style-type: none"> Oven must be installed level. Hood installation is required. Water supply shut-off valve and back-flow preventer when required by local code. 															

ELECTRICAL (NO CORD, NO PLUG, DEDICATED CIRCUIT REQUIRED) DO NOT CONNECT TO G.F.I. OUTLET								
MODEL	VOLTAGE	PH	HZ	AMPS	kW	BREAKER	AWG	CONNECTION
CTC7-20E	208 – 240	3	50/60	45.7 – 52.7	16.5 – 21.9	50-60	4 – 3	L1, L2, L3, G
	380 – 415	3	50	28 – 30.4	18.7 – 21.9	32	6 – 4	L1, L2, L3, N, G
	440 – 480	3*	60	24.1 – 26.3	18.8 – 21.9	25-30	8	L1, L2, L3, G

*ELECTRICAL SERVICE CHARGE APPLIES

WEIGHT	SHIP DIMENSIONS	PAN CAPACITY
NET 680 lbs est 308 kg	(L x W x H) 56" x 48" x 51"*	FULL-SIZE: 20" x 12" x 2-1/2" Fourteen (14)
SHIP 720 lbs* 327 kg*	(1422 x 1219 x 1295mm)*	*ON WIRE GN 1/1: 530 x 325 x 65mm Fourteen (14)
*DOMESTIC GROUND SHIPPING INFORMATION. CONTACT FACTORY FOR EXPORT WEIGHT AND DIMENSIONS.		SHELVES ONLY GN 2/1: 650 x 530 x 65mm Seven (7)
		*FULL-SIZE SHEET: 18" x 26" x 1" Seven (7)
		PRODUCT MAXIMUM: 168 lb (76 kg)
		VOLUME MAXIMUM: 105 quarts (133 liters)
		*ADDITIONAL WIRE SHELVES REQUIRED FOR MAXIMUM CAPACITY

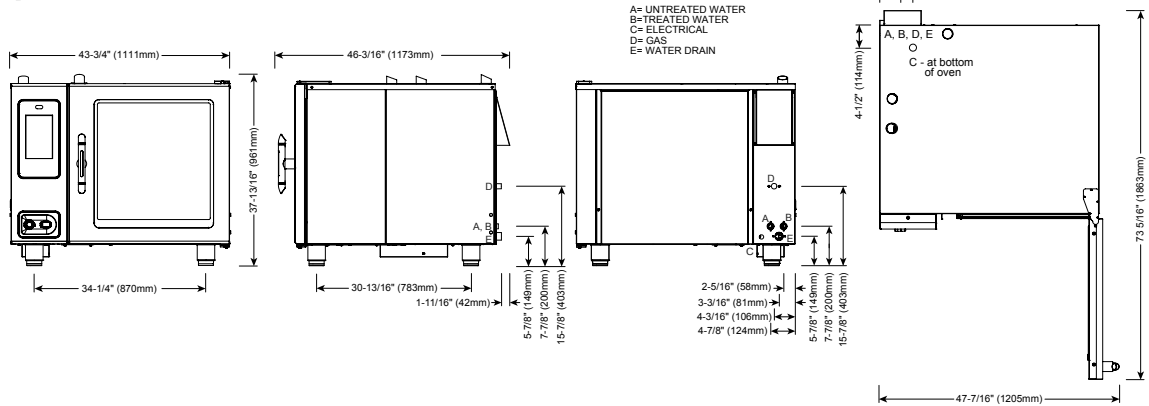

DIMENSIONS: H x W x D	
EXTERIOR:	37-13/16" x 43-3/4" x 46-3/16" (961mm x 1111mm x 1173mm)
EXTERIOR WITH RECESSED DOOR:	37-13/16" x 47-3/4" x 46-3/16" (961mm x 1213mm x 1173mm)
INTERIOR:	23-1/4" x 24-1/4" x 32-3/4" (590mm x 616mm x 832mm)

WATER REQUIREMENTS	
TWO (2) COLD WATER INLETS - DRINKING QUALITY	
ONE (1) TREATED WATER INLET:	3/4" NPT* * Can manifold off of one 3/4" line.
ONE (1) UNTREATED WATER INLET:	3/4" NPT*
LINE PRESSURE:	30 to 90 psi 2.1 to 6.3 bar
WATER DRAIN: 1-1/2" (40mm) CONNECTION WITH A 2" MINIMUM AIR GAP INSTALLED AS CLOSE TO THE OVEN AS POSSIBLE. MATERIALS MUST WITHSTAND TEMPERATURES UP TO 200°F (93°C).	
CLEARANCE REQUIREMENTS	
LEFT:	0" (0mm) 18" (457mm) FOR SERVICE ACCESS
RIGHT:	0" (0mm) NON-COMBUSTIBLE SURFACES 2" (51mm) COMBUSTIBLE SURFACES
TOP:	20" (508mm) FOR AIR MOVEMENT
BACK:	4" (102mm) BOTTOM: 5-1/8" (130mm) FOR LEGS, AIR INTAKE
INSTALLATION REQUIREMENTS	
• Oven must be installed level. • Hood installation is required.	
• Water supply shut-off valve and back-flow preventer when required by local code.	

WATER QUALITY STANDARDS	
It is the sole responsibility of the owner/operator/purchaser of this equipment to verify that the incoming water supply is comprehensively tested and if required, a means of "water treatment" provided that would meet compliance requirements with the published water quality standards published below. Non-compliance with these minimum standards will potentially damage this equipment and/or components and VOID the original equipment manufacturer's warranty. Alto-Shaam recommends using OptiPure® [www.optipurewater.com] products to properly treat your water.	
Contaminant	Inlet Water Requirements
Free Chlorine	Less than 0.1 ppm (mg/L)
Hardness	30-70 ppm
Chloride	Less than 30 ppm (mg/L)
pH	7.0 to 8.5
Silica	Less than 12 ppm (mg/L)
Total Dissolved Solids (tds)	50-125 ppm

GAS REQUIREMENTS (GAS TYPE MUST BE SPECIFIED ON ORDER)	
HOOK-UP:	3/4" NPT Alternate burner orifice is required for installation sites at elevations of 2,000 feet (610m) above sea level

RATED THERMAL LOAD		CONNECTED PRESSURE			
NORTH AMERICA	INTERNATIONAL	NORTH AMERICA		INTERNATIONAL	
Natural Gas/Propane	G20, G25, G31	Natural Gas	Propane	G20	20mbar
Gross Heating Value (HHV)	Net Heating Value (LHV)	Minimum: 5.5" W.C.	Minimum: 9" W.C.	G25	20mbar
98,000 Btu / hr	26.5 kW	Maximum: 14" W.C.	Maximum: 14" W.C.	G31	30mbar

ELECTRICAL - CTP7-20G (DEDICATED CIRCUIT REQUIRED) DO NOT CONNECT TO A G.F.I. OUTLET								WITH COMBISMOKER® OPTION				
VOLTAGE	PH	HZ	AWG	CONNECTION no cord, no plug	AMPS	BREAKER	KW	CONNECTION no cord, no plug	AMPS	BREAKER	KW	
↻	120	1	60	14	L1, N, G	6.8	20	.84	L1, N, G	12.0	20	1.46
↻	208 – 240	1†	50/60	14	L1, L2/N, G	4.8 – 4.2	15	1.0	L1, L2/N, G	7.3 – 7.1	15	1.5 – 1.7
↻	208 – 240	3	50/60	14	L1, L2, L3, G	4.8 – 4.2	15	1.0	L1, L2, L3, G	7.3 – 7.1	15	1.5 – 1.7
↻	380 – 415	3	50	14	L1, L2, L3, N, G	4.6 – 4.2	15	1.0	L1, L2, L3, N, G	7.2 – 7.1	15	1.6 – 1.7

↻ NORTH AMERICA VOLTAGE CHOICE ↻ INTERNATIONAL VOLTAGE CHOICE †ELECTRICAL SERVICE CHARGE APPLIES

WEIGHT	SHIP DIMENSIONS		PAN CAPACITY			
NET 680 lbs est 308 kg	(L x W x H) 56" x 48" x 51"*		FULL-SIZE:	20" x 12" x 2-1/2"	Fourteen (14)	PRODUCT MAXIMUM: 168 lb (76 kg)
SHIP 720 lbs* 327 kg*	(1422 x 1219 x 1295mm)*		GN 1/1:	530 x 325 x 65mm	Fourteen (14)	VOLUME MAXIMUM: 105 quarts (133 liters)
*DOMESTIC GROUND SHIPPING INFORMATION. CONTACT FACTORY FOR EXPORT WEIGHT AND DIMENSIONS.			GN 2/1:	650 x 530 x 65mm	Seven (7)	*ADDITIONAL WIRE SHELVES REQUIRED FOR MAXIMUM CAPACITY
			*FULL-SIZE SHEET:	18" x 26" x 1"	Seven (7)	

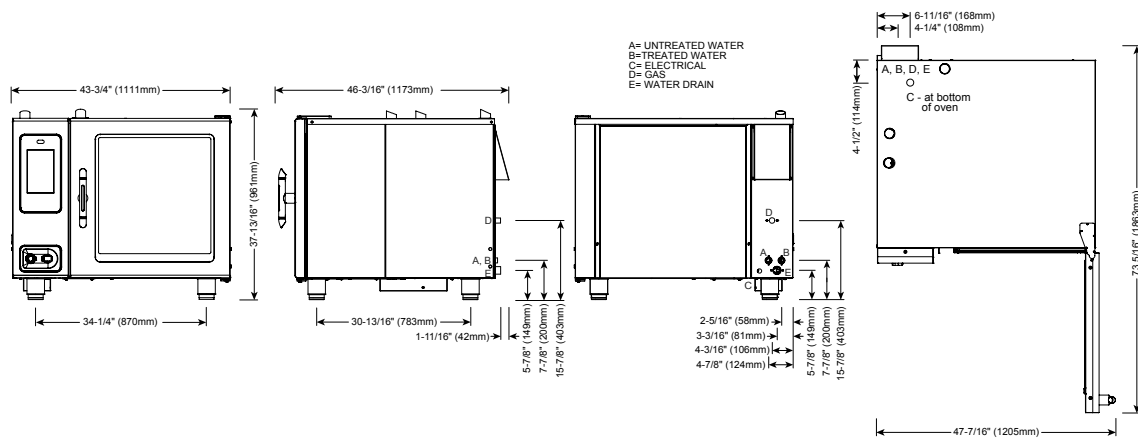

DIMENSIONS: H x W x D

EXTERIOR:

37-13/16" x 43-3/4" x 46-3/16" (961mm x 1111mm x 1173mm)

EXTERIOR WITH RECESSED DOOR:

37-13/16" x 47-3/4" x 46-3/16" (961mm x 1213mm x 1173mm)

INTERIOR:

23-1/4" x 24-1/4" x 32-3/4" (590mm x 616mm x 832mm)

WATER REQUIREMENTS

TWO (2) COLD WATER INLETS - DRINKING QUALITY

ONE (1) TREATED WATER INLET: 3/4" NPT* * Can manifold off of one 3/4" line.
ONE (1) UNTREATED WATER INLET: 3/4" NPT*
LINE PRESSURE: 30 to 90 psi 2.1 to 6.3 bar
WATER DRAIN: 1-1/2" (40mm) CONNECTION WITH A 2" MINIMUM AIR GAP INSTALLED AS CLOSE TO THE OVEN AS POSSIBLE. MATERIALS MUST WITHSTAND TEMPERATURES UP TO 200°F (93°C).

CLEARANCE REQUIREMENTS

LEFT: 0" (0mm) 18" (457mm) FOR SERVICE ACCESS
RIGHT: 0" (0mm) NON-COMBUSTIBLE SURFACES 2" (51mm) COMBUSTIBLE SURFACES
TOP: 20" (508mm) FOR AIR MOVEMENT
BACK: 4" (102mm) **BOTTOM:** 5-1/8" (130mm) FOR LEGS, AIR INTAKE

INSTALLATION REQUIREMENTS

- Oven must be installed level.
- Hood installation is required.
- Water supply shut-off valve and back-flow preventer when required by local code.

WATER QUALITY STANDARDS

It is the sole responsibility of the owner/operator/purchaser of this equipment to verify that the incoming water supply is comprehensively tested and if required, a means of "water treatment" provided that would meet compliance requirements with the published water quality standards published below. Non-compliance with these minimum standards will potentially damage this equipment and/or components and VOID the original equipment manufacturer's warranty. Alto-Shaam recommends using OptiPure® [www.optipurewater.com] products to properly treat your water.

Contaminant Inlet Water Requirements

Free Chlorine	Less than 0.1 ppm (mg/L)
Hardness	30-70 ppm
Chloride	Less than 30 ppm (mg/L)
pH	7.0 to 8.5
Silica	Less than 12 ppm (mg/L)
Total Dissolved Solids (tds)	50-125 ppm

GAS REQUIREMENTS (GAS TYPE MUST BE SPECIFIED ON ORDER)

HOOK-UP: 3/4" NPT Alternate burner orifice is required for installation sites at elevations of 2,000 feet (610m) above sea level

RATED THERMAL LOAD

CONNECTED PRESSURE

NORTH AMERICA		INTERNATIONAL		NORTH AMERICA		INTERNATIONAL	
Natural Gas/Propane		G20, G25, G31		Natural Gas	Propane	G20	20mbar
Gross Heating Value (HHV)		Net Heating Value (LHV)		Minimum: 5.5" W.C.	Minimum: 9" W.C.	G25	20mbar
85,000 Btu / hr		22.5 kW		Maximum: 14" W.C.	Maximum: 14" W.C.	G31	30mbar

ELECTRICAL - CTC7-20G (DEDICATED CIRCUIT REQUIRED) DO NOT CONNECT TO A G.F.I. OUTLET

	VOLTAGE	PH	HZ	AWG	CONNECTION	AMPS	BREAKER	KW
↻	120	1	60	14	L1, N, G - no cord, no plug	7.0	20	.84
↻	208 - 240	3	50/60	14	L1, L2, L3, G - no cord, no plug	4.8 - 4.2	15	1.0
↻	380 - 415	3	50	14	L1, L2, L3, N, G - no cord, no plug	4.6 - 4.2	15	1.0

↻ NORTH AMERICA VOLTAGE CHOICE ↻ INTERNATIONAL VOLTAGE CHOICE

WEIGHT	SHIP DIMENSIONS	PAN CAPACITY		PRODUCT MAXIMUM: 168 lb (76 kg)	
NET 680 lbs est 308 kg	(L x W x H) 56" x 48" x 51"	FULL-SIZE:	20" x 12" x 2-1/2"	Fourteen (14)	VOLUME MAXIMUM: 105 quarts (133 liters)
SHIP 720 lbs* 327 kg*	(1422 x 1219 x 1295mm)*	*ON WIRE	GN 1/1: 530 x 325 x 65mm	Fourteen (14)	
		SHELVES ONLY	GN 2/1: 650 x 530 x 65mm	Seven (7)	*ADDITIONAL WIRE SHELVES REQUIRED FOR MAXIMUM CAPACITY
		*FULL-SIZE SHEET:	18" x 26" x 1"	Seven (7)	

*DOMESTIC GROUND SHIPPING INFORMATION. CONTACT FACTORY FOR EXPORT WEIGHT AND DIMENSIONS.

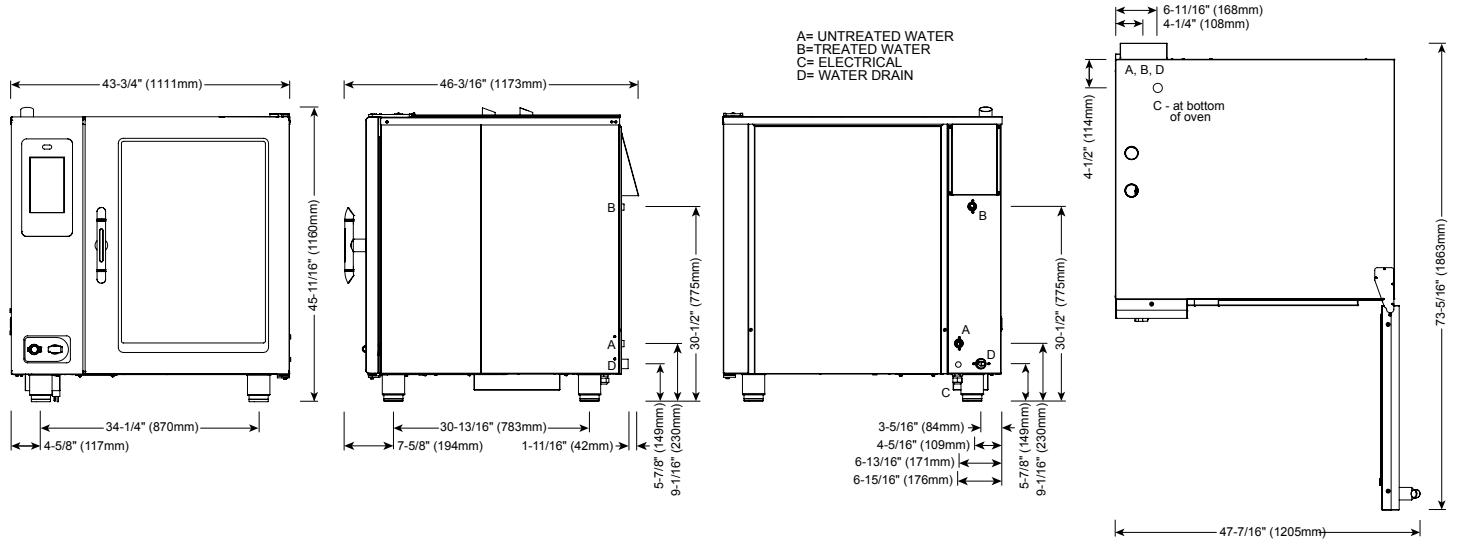

IP X5



DIMENSIONS: H x W x D
EXTERIOR: 45-11/16" x 43-3/4" x 46-3/16" (1160mm x 1111mm x 1173mm)
EXTERIOR WITH RECESSED DOOR: 45-11/16" x 47-3/4" x 46-3/16" (1160mm x 1213mm x 1173mm)
INTERIOR: 31-1/2" x 24-1/4" x 32-3/4" (800mm x 616mm x 832mm)

WATER REQUIREMENTS

TWO (2) COLD WATER INLETS - DRINKING QUALITY
ONE (1) TREATED WATER INLET: 3/4" NPT* * Can manifold off of one
ONE (1) UNTREATED WATER INLET: 3/4" NPT* 3/4" line.
LINE PRESSURE: 30 to 90 psi 2.1 to 6.3 bar
WATER DRAIN: 1-1/2" (40mm) CONNECTION WITH A 2" MINIMUM AIR GAP INSTALLED AS CLOSE TO THE OVEN AS POSSIBLE. MATERIALS MUST WITHSTAND TEMPERATURES UP TO 200°F (93°C).

CLEARANCE REQUIREMENTS

LEFT: 0" (0mm) 18" (457mm) FOR SERVICE ACCESS
RIGHT: 0" (0mm) NON-COMBUSTIBLE SURFACES 2" (51mm) COMBUSTIBLE SURFACES
TOP: 20" (508mm) FOR AIR MOVEMENT
BACK: 4" (102mm) BOTTOM: 5-1/8" (130mm) FOR LEGS, AIR INTAKE

INSTALLATION REQUIREMENTS

- Oven must be installed level.
- Hood installation is required.
- Water supply shut-off valve and back-flow preventer when required by local code.

WATER QUALITY STANDARDS

It is the sole responsibility of the owner/operator/purchaser of this equipment to verify that the incoming water supply is comprehensively tested and if required, a means of "water treatment" provided that would meet compliance requirements with the published water quality standards published below. Non-compliance with these minimum standards will potentially damage this equipment and/or components and VOID the original equipment manufacturer's warranty. Alto-Shaam recommends using OptiPure® [www.optipurewater.com] products to properly treat your water.

Contaminant	Inlet Water Requirements
Free Chlorine	Less than 0.1 ppm (mg/L)
Hardness	30-70 ppm
Chloride	Less than 30 ppm (mg/L)
pH	7.0 to 8.5
Silica	Less than 12 ppm (mg/L)
Total Dissolved Solids (tds)	50-125 ppm

ELECTRICAL - CTP10-20E (NO CORD, NO PLUG, DEDICATED CIRCUIT REQUIRED) DO NOT CONNECT TO A G.F.I. OUTLET											WITH COMBISMOKER® OPTION					
					ECO STANDARD			**PROpower™ OPTION			ECO STANDARD			**PROpower™ OPTION		
VOLTAGE	PH	HZ	AWG	CONNECTION	AMPS	KW	BREAKER	AMPS	KW	BREAKER	AMPS	KW	BREAKER	AMPS	KW	BREAKER
208-240	3	50/60	2-1	L1, L2, L3, G	68.8-79.4	24.8-33	70-80	88.7-102.3	28.9-38.5	90-110	71.3-82.3	25.3-33.7	80-90	91.2-105.2	29.4-39.2	100-110
380-415	3	50	4-3	L1, L2, L3, N, G	42.1-45.8	28.2-33	63	63.2-68.8	32.3-38.5	63-80	44.8-48.7	28.8-33.7	63	65.8-71.6	32.9-39.2	100
440-480	3*	60	6-4	L1, L2, L3, G	36.4-39.7	28.3-33	40	46.9-51.2	32.4-38.5	50-60	37.7-41.1	28.8-33.7	40-50	48.2-52.6	33-39.2	50-60

*ELECTRICAL SERVICE CHARGE APPLIES

**NO-COST OPTION ON ELECTRIC MODELS

WEIGHT	SHIP DIMENSIONS	PAN CAPACITY	PRODUCT MAXIMUM:
NET 760 lbs est 345 kg	(L x W x H) 56" x 48" x 65"	FULL-SIZE: 20" x 12" x 2-1/2"	240 lb (109 kg)
SHIP 800 lbs* 363 kg*	(1422 x 1219 x 1651mm)*	*ON WIRE GN 1/1: 530 x 325 x 65mm	VOLUME MAXIMUM: 150 quarts (190 liters)
*DOMESTIC GROUND SHIPPING INFORMATION. CONTACT FACTORY FOR EXPORT WEIGHT AND DIMENSIONS.		SHELVES ONLY GN 2/1: 650 x 530 x 65mm	*ADDITIONAL WIRE SHELVES REQUIRED FOR MAXIMUM CAPACITY
		*FULL-SIZE SHEET: 18" x 26" x 1"	

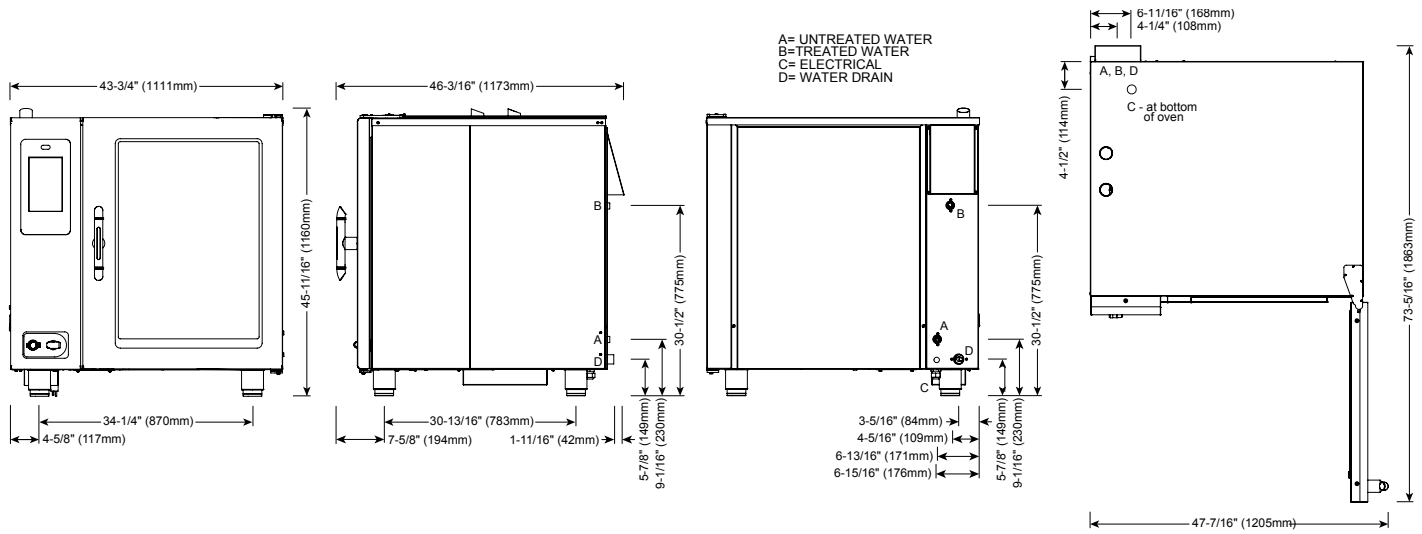

DIMENSIONS: H x W x D
EXTERIOR: 45-11/16" x 43-3/4" x 46-3/16" (1160mm x 1111mm x 1173mm)
EXTERIOR WITH RECESSED DOOR: 45-11/16" x 47-3/4" x 46-3/16" (1160mm x 1213mm x 1173mm)
INTERIOR: 31-1/2" x 24-1/4" x 32-3/4" (800mm x 616mm x 832mm)

<p>WATER REQUIREMENTS</p> <p>TWO (2) COLD WATER INLETS - DRINKING QUALITY</p> <p>ONE (1) TREATED WATER INLET: 3/4" NPT* * Can manifold off of one 3/4" line.</p> <p>ONE (1) UNTREATED WATER INLET: 3/4" NPT*</p> <p>LINE PRESSURE: 30 to 90 psi 2.1 to 6.3 bar</p> <p>WATER DRAIN: 1-1/2" (40mm) CONNECTION WITH A 2" MINIMUM AIR GAP INSTALLED AS CLOSE TO THE OVEN AS POSSIBLE. MATERIALS MUST WITHSTAND TEMPERATURES UP TO 200°F (93°C).</p> <p>CLEARANCE REQUIREMENTS</p> <p>LEFT: 0" (0mm) 18" (457mm) FOR SERVICE ACCESS</p> <p>RIGHT: 0" (0mm) NON-COMBUSTIBLE SURFACES 2" (51mm) COMBUSTIBLE SURFACES</p> <p>TOP: 20" (508mm) FOR AIR MOVEMENT</p> <p>BACK: 4" (102mm) BOTTOM: 5-1/8" (130mm) FOR LEGS, AIR INTAKE</p> <p>INSTALLATION REQUIREMENTS</p> <ul style="list-style-type: none"> Oven must be installed level. Hood installation is required. Water supply shut-off valve and back-flow preventer when required by local code. 	<p>WATER QUALITY STANDARDS</p> <p>It is the sole responsibility of the owner/operator/purchaser of this equipment to verify that the incoming water supply is comprehensively tested and if required, a means of "water treatment" provided that would meet compliance requirements with the published water quality standards published below. Non-compliance with these minimum standards will potentially damage this equipment and/or components and VOID the original equipment manufacturer's warranty. Alto-Shaam recommends using OptiPure® [www.optipurewater.com] products to properly treat your water.</p> <table border="1"> <thead> <tr> <th>Contaminant</th> <th>Inlet Water Requirements</th> </tr> </thead> <tbody> <tr> <td>Free Chlorine</td> <td>Less than 0.1 ppm (mg/L)</td> </tr> <tr> <td>Hardness</td> <td>30-70 ppm</td> </tr> <tr> <td>Chloride</td> <td>Less than 30 ppm (mg/L)</td> </tr> <tr> <td>pH</td> <td>7.0 to 8.5</td> </tr> <tr> <td>Silica</td> <td>Less than 12 ppm (mg/L)</td> </tr> <tr> <td>Total Dissolved Solids (tds)</td> <td>50-125 ppm</td> </tr> </tbody> </table>	Contaminant	Inlet Water Requirements	Free Chlorine	Less than 0.1 ppm (mg/L)	Hardness	30-70 ppm	Chloride	Less than 30 ppm (mg/L)	pH	7.0 to 8.5	Silica	Less than 12 ppm (mg/L)	Total Dissolved Solids (tds)	50-125 ppm
Contaminant	Inlet Water Requirements														
Free Chlorine	Less than 0.1 ppm (mg/L)														
Hardness	30-70 ppm														
Chloride	Less than 30 ppm (mg/L)														
pH	7.0 to 8.5														
Silica	Less than 12 ppm (mg/L)														
Total Dissolved Solids (tds)	50-125 ppm														

ELECTRICAL (NO CORD, NO PLUG, DEDICATED CIRCUIT REQUIRED) DO NOT CONNECT TO G.F.I OUTLET									
MODEL	VOLTAGE	PH	HZ	AMPS	kW	BREAKER	AWG	CONNECTION	
CTC10-20E	208 – 240	3	50/60	68.8 – 79.4	24.8 – 33.0	70-80	2 – 1	L1, L2, L3, G	
	380 – 415	3	50	42.1 – 45.8	28.2 – 33.0	63	4 – 3	L1, L2, L3, N, G	
	440 – 480	3*	60	36.4 – 39.7	28.3 – 33.0	40	6 – 4	L1, L2, L3, G	

*ELECTRICAL SERVICE CHARGE APPLIES

WEIGHT	SHIP DIMENSIONS	PAN CAPACITY			
NET 760 lbs est 345 kg	(L x W x H) 56" x 48" x 65"*	FULL-SIZE:	20" x 12" x 2-1/2"	Twenty (20)	PRODUCT MAXIMUM: 240 lb (109 kg)
SHIP 800 lbs* 363 kg*	(1422 x 1219 x 1651mm)*	*ON WIRE	GN 1/1: 530 x 325 x 65mm	Twenty (20)	VOLUME MAXIMUM: 150 quarts (190 liters)
*DOMESTIC GROUND SHIPPING INFORMATION. CONTACT FACTORY FOR EXPORT WEIGHT AND DIMENSIONS.		SHELVES ONLY	GN 2/1: 650 x 530 x 65mm	Ten (10)	*ADDITIONAL WIRE SHELVES REQUIRED FOR MAXIMUM CAPACITY
		*FULL-SIZE SHEET:	18" x 26" x 1"	Ten (10)	

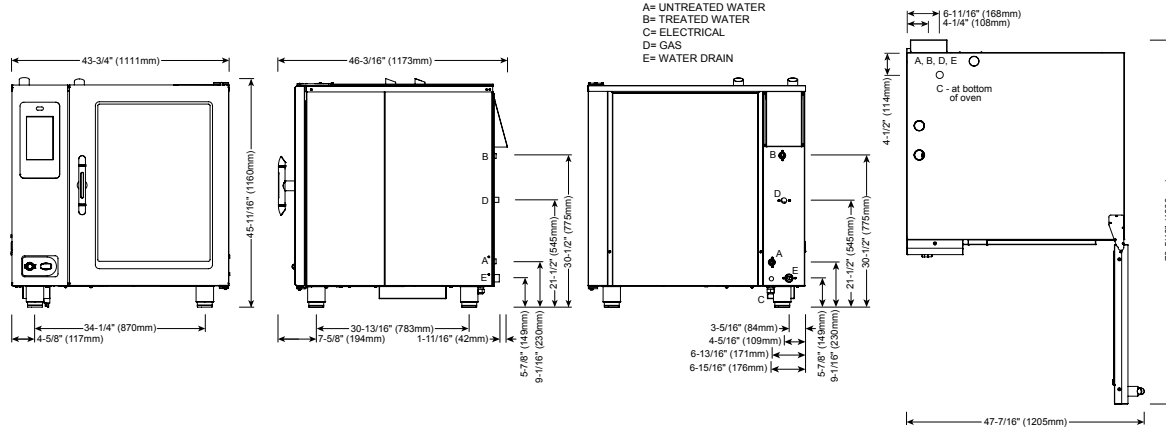

DIMENSIONS: H x W x D
EXTERIOR: 45-11/16" x 43-3/4" x 46-3/16" (1160mm x 1111mm x 1173mm)
EXTERIOR WITH RECESSED DOOR: 45-11/16" x 47-3/4" x 46-3/16" (1160mm x 1213mm x 1173mm)
INTERIOR: 31-1/2" x 24-1/4" x 32-3/4" (800mm x 616mm x 832mm)

WATER REQUIREMENTS
TWO (2) COLD WATER INLETS - DRINKING QUALITY ONE (1) TREATED WATER INLET: 3/4" NPT* * Can manifold off of one ONE (1) UNTREATED WATER INLET: 3/4" NPT* 3/4" line. LINE PRESSURE: 30 to 90 psi 2.1 to 6.3 bar WATER DRAIN: 1-1/2" (40mm) CONNECTION WITH A 2" MINIMUM AIR GAP INSTALLED AS CLOSE TO THE OVEN AS POSSIBLE. MATERIALS MUST WITHSTAND TEMPERATURES UP TO 200°F (93°C).
CLEARANCE REQUIREMENTS
LEFT: 0" (0mm) 18" (457mm) FOR SERVICE ACCESS
RIGHT: 0" (0mm) NON-COMBUSTIBLE SURFACES 2" (51mm) COMBUSTIBLE SURFACES
TOP: 20" (508mm) FOR AIR MOVEMENT
BACK: 4" (102mm) BOTTOM: 5-1/8" (130mm) FOR LEGS, AIR INTAKE
INSTALLATION REQUIREMENTS
• Oven must be installed level. • Hood installation is required. • Water supply shut-off valve and back-flow preventer when required by local code.

WATER QUALITY STANDARDS
It is the sole responsibility of the owner/operator/purchaser of this equipment to verify that the incoming water supply is comprehensively tested and if required, a means of "water treatment" provided that would meet compliance requirements with the published water quality standards published below. Non-compliance with these minimum standards will potentially damage this equipment and/or components and VOID the original equipment manufacturer's warranty. Alto-Shaam recommends using OptiPure® [www.optipurewater.com] products to properly treat your water.
Contaminant Inlet Water Requirements
Free Chlorine Less than 0.1 ppm (mg/L)
Hardness 30-70 ppm
Chloride Less than 30 ppm (mg/L)
pH 7.0 to 8.5
Silica Less than 12 ppm (mg/L)
Total Dissolved Solids (tds) 50-125 ppm

GAS REQUIREMENTS (GAS TYPE MUST BE SPECIFIED ON ORDER)
HOOK-UP: 3/4" NPT Alternate burner orifice is required for installation sites at elevations of 2,000 feet (610m) above sea level

RATED THERMAL LOAD		CONNECTED PRESSURE			
NORTH AMERICA	INTERNATIONAL	NORTH AMERICA		INTERNATIONAL	
Natural Gas/Propane	G20, G25, G31	Natural Gas	Propane	G20	20mbar
Gross Heating Value (HHV) 133,000 Btu / hr	Net Heating Value (LHV) 36.0 kW	Minimum: 5.5" W.C. Maximum: 14" W.C.	Minimum: 9" W.C. Maximum: 14" W.C.	G25	20mbar
				G31	30mbar

ELECTRICAL - CTP10-20G (DEDICATED CIRCUIT REQUIRED) DO NOT CONNECT TO A G.F.I. OUTLET								WITH COMBISMOKER® OPTION				
VOLTAGE	PH	HZ	AWG	CONNECTION no cord, no plug	AMPS	BREAKER	kW	CONNECTION no cord, no plug	AMPS	BREAKER	kW	
↔	120	1	60	14	L1, N, G	6.8	20	.84	L1, N, G	12.0	20	1.46
↔	208 - 240	1 [†]	50/60	14	L1, L2/N, G	4.8 - 4.2	15	1.0	L1, L2/N, G	7.3 - 7.1	15	1.5 - 1.7
↔	208 - 240	3	50/60	14	L1, L2, L3, G	4.8 - 4.2	15	1.0	L1, L2, L3, G	7.3 - 7.1	15	1.5 - 1.7
↔	380 - 415	3	50	14	L1, L2, L3, N, G	4.6 - 4.2	15	1.0	L1, L2, L3, N, G	7.2 - 7.1	15	1.6 - 1.7

↔ NORTH AMERICA VOLTAGE CHOICE ↔ INTERNATIONAL VOLTAGE CHOICE †ELECTRICAL SERVICE CHARGE APPLIES

WEIGHT	SHIP DIMENSIONS	PAN CAPACITY	PRODUCT MAXIMUM:
NET 760 lbs est 345 kg	(L x W x H) 56" x 48" x 65"*	FULL-SIZE: 20" x 12" x 2-1/2" Twenty (20)	240 lb (109 kg)
SHIP 800 lbs* 363 kg*	(1422 x 1219 x 1651mm)*	*ON WIRE GN 1/1: 530 x 325 x 65mm Twenty (20)	VOLUME MAXIMUM: 150 quarts (190 liters)
*DOMESTIC GROUND SHIPPING INFORMATION. CONTACT FACTORY FOR EXPORT WEIGHT AND DIMENSIONS.		SHELVES ONLY GN 2/1: 650 x 530 x 65mm Ten (10)	*ADDITIONAL WIRE SHELVES REQUIRED FOR MAXIMUM CAPACITY
		*FULL-SIZE SHEET: 18" x 26" x 1" Ten (10)	

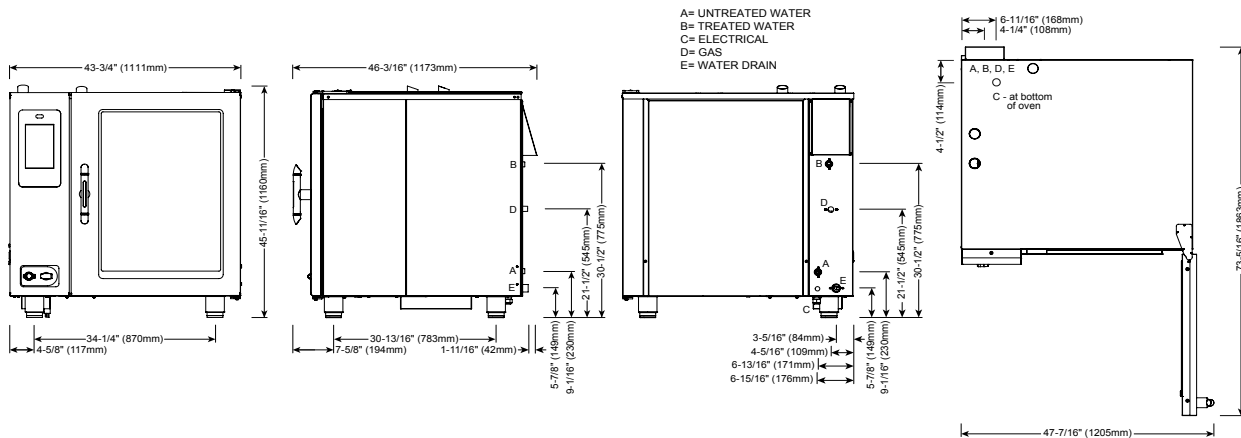

DIMENSIONS: H x W x D
EXTERIOR: 45-11/16" x 43-3/4" x 46-3/16" (1160mm x 1111mm x 1173mm)
EXTERIOR WITH RECESSED DOOR: 45-11/16" x 47-3/4" x 46-3/16" (1160mm x 1213mm x 1173mm)
INTERIOR: 31-1/2" x 24-1/4" x 32-3/4" (800mm x 616mm x 832mm)



WATER REQUIREMENTS
TWO (2) COLD WATER INLETS - DRINKING QUALITY
ONE (1) TREATED WATER INLET: 3/4" NPT* * Can manifold off of one 3/4" line.
ONE (1) UNTREATED WATER INLET: 3/4" NPT*
LINE PRESSURE: 30 to 90 psi 2.1 to 6.3 bar
WATER DRAIN: 1-1/2" (40mm) CONNECTION WITH A 2" MINIMUM AIR GAP INSTALLED AS CLOSE TO THE OVEN AS POSSIBLE. MATERIALS MUST WITHSTAND TEMPERATURES UP TO 200°F (93°C).
CLEARANCE REQUIREMENTS
LEFT: 0" (0mm) 18" (457mm) FOR SERVICE ACCESS
RIGHT: 0" (0mm) NON-COMBUSTIBLE SURFACES 2" (51mm) COMBUSTIBLE SURFACES
TOP: 20" (508mm) FOR AIR MOVEMENT
BACK: 4" (102mm) BOTTOM: 5-1/8" (130mm) FOR LEGS, AIR INTAKE
INSTALLATION REQUIREMENTS
• Oven must be installed level. • Hood installation is required.
• Water supply shut-off valve and back-flow preventer when required by local code.

WATER QUALITY STANDARDS
It is the sole responsibility of the owner/operator/purchaser of this equipment to verify that the incoming water supply is comprehensively tested and if required, a means of "water treatment" provided that would meet compliance requirements with the published water quality standards published below. Non-compliance with these minimum standards will potentially damage this equipment and/or components and VOID the original equipment manufacturer's warranty. Alto-Shaam recommends using OptiPure® [www.optipurewater.com] products to properly treat your water.
Contaminant Inlet Water Requirements
Free Chlorine Less than 0.1 ppm (mg/L)
Hardness 30-70 ppm
Chloride Less than 30 ppm (mg/L)
pH 7.0 to 8.5
Silica Less than 12 ppm (mg/L)
Total Dissolved Solids (tds) 50-125 ppm

GAS REQUIREMENTS (GAS TYPE MUST BE SPECIFIED ON ORDER)
HOOK-UP: 3/4" NPT Alternate burner orifice is required for installation sites at elevations of 2,000 feet (610m) above sea level

RATED THERMAL LOAD		CONNECTED PRESSURE			
NORTH AMERICA	INTERNATIONAL	NORTH AMERICA		INTERNATIONAL	
Natural Gas/Propane	G20, G25, G31	Natural Gas	Propane	G20	20mbar
Gross Heating Value (HHV)	Net Heating Value (LHV)	Minimum: 5.5" W.C.	Minimum: 9" W.C.	G25	20mbar
121,000 Btu / hr	32.0 kW	Maximum: 14" W.C.	Maximum: 14" W.C.	G31	30mbar

ELECTRICAL - CTC10-20G (DEDICATED CIRCUIT REQUIRED) DO NOT CONNECT TO A G.F.I. OUTLET								
	VOLTAGE	PH	HZ	AWG	CONNECTION	AMPS	BREAKER	kW
☞	120	1	60	14	L1, N, G - no cord, no plug	7.0	20	.84
☞	208 - 240	3	50/60	14	L1, L2, L3, G - no cord, no plug	4.8 - 4.2	15	1.0
☞	380 - 415	3	50	14	L1, L2, L3, N, G - no cord, no plug	4.6 - 4.2	15	1.0

☞ NORTH AMERICA VOLTAGE CHOICE ☞ INTERNATIONAL VOLTAGE CHOICE

WEIGHT	SHIP DIMENSIONS	PAN CAPACITY	
NET 760 lbs est 345 kg	(L x W x H) 56" x 48" x 65"	FULL-SIZE: 20" x 12" x 2-1/2"	Twenty (20)
SHIP 800 lbs* 363 kg*	(1422 x 1219 x 1651mm)*	*ON WIRE GN 1/1: 530 x 325 x 65mm	Twenty (20)
		SHELVES ONLY GN 2/1: 650 x 530 x 65mm	Ten (10)
		*FULL-SIZE SHEET: 18" x 26" x 1"	Ten (10)
*DOMESTIC GROUND SHIPPING INFORMATION. CONTACT FACTORY FOR EXPORT WEIGHT AND DIMENSIONS.		PRODUCT MAXIMUM: 240 lb (109 kg)	
		VOLUME MAXIMUM: 150 quarts (190 liters)	
		*ADDITIONAL WIRE SHELVES REQUIRED FOR MAXIMUM CAPACITY	

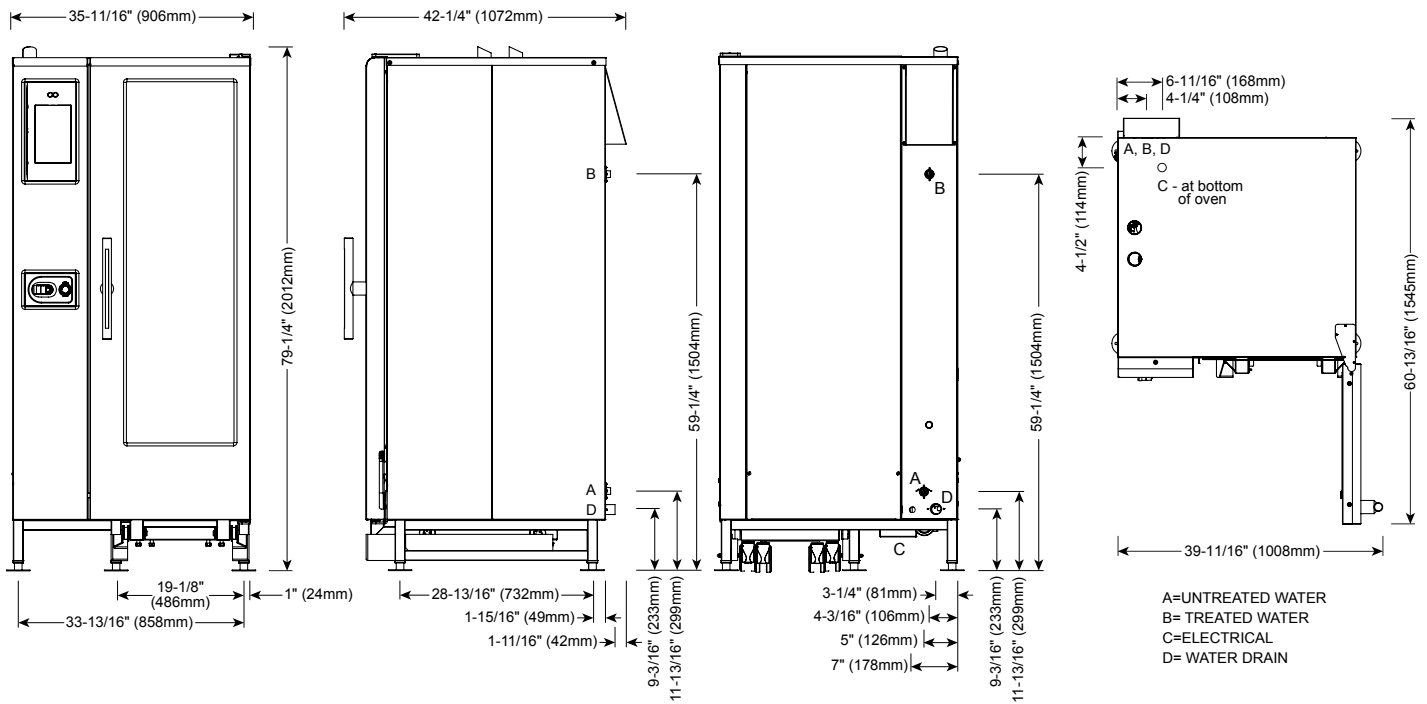

A=UNTREATED WATER
B=TREATED WATER
C=ELECTRICAL
D= WATER DRAIN



DIMENSIONS: H x W x D
EXTERIOR: 79-1/4" x 35-11/16" x 42-1/4" (2012mm x 906mm x 1072mm)
EXTERIOR WITH RECESSED DOOR: 79-1/4" x 39-11/16" x 42-1/4" (2012mm x 1008mm x 1072mm)
INTERIOR: 60-7/16" x 16-1/4" x 28-1/16" (1535mm x 411mm x 712mm)

WATER REQUIREMENTS	
TWO (2) COLD WATER INLETS - DRINKING QUALITY	
ONE (1) TREATED WATER INLET: 3/4" NPT*	* Can manifold off of one 3/4" line.
ONE (1) UNTREATED WATER INLET: 3/4" NPT*	
LINE PRESSURE: 30 to 90 psi	2.1 to 6.3 bar
WATER DRAIN: 1-1/2" (40mm) CONNECTION WITH A 2" MINIMUM AIR GAP INSTALLED AS CLOSE TO THE OVEN AS POSSIBLE. MATERIALS MUST WITHSTAND TEMPERATURES UP TO 200°F (93°C).	
CLEARANCE REQUIREMENTS	
LEFT: 0" (0mm)	18" (457mm) FOR SERVICE ACCESS
RIGHT: 0" (0mm)	NON-COMBUSTIBLE SURFACES 2" (51mm) COMBUSTIBLE SURFACES
TOP: 20" (508mm) FOR AIR MOVEMENT	
BACK: 4" (102mm)	BOTTOM: 5-1/8" (130mm) FOR LEGS, AIR INTAKE
INSTALLATION REQUIREMENTS	
• Oven must be installed level. • Hood installation is required.	
• Water supply shut-off valve and back-flow preventer when required by local code.	

WATER QUALITY STANDARDS	
It is the sole responsibility of the owner/operator/purchaser of this equipment to verify that the incoming water supply is comprehensively tested and if required, a means of "water treatment" provided that would meet compliance requirements with the published water quality standards published below. Non-compliance with these minimum standards will potentially damage this equipment and/or components and VOID the original equipment manufacturer's warranty. Alto-Shaam recommends using OptiPure® [www.optipurewater.com] products to properly treat your water.	
Contaminant	Inlet Water Requirements
Free Chlorine	Less than 0.1 ppm (mg/L)
Hardness	30-70 ppm
Chloride	Less than 30 ppm (mg/L)
pH	7.0 to 8.5
Silica	Less than 12 ppm (mg/L)
Total Dissolved Solids (tds)	50-125 ppm

ELECTRICAL - CTP20-10E (NO CORD, NO PLUG, DEDICATED CIRCUIT REQUIRED) DO NOT CONNECT TO A G.F.I. OUTLET										WITH COMBISMOKER® OPTION						
					ECO STANDARD			**PROpower™ OPTION			ECO STANDARD			**PROpower™ OPTION		
VOLTAGE	PH	HZ	AWG	CONNECTION	AMPS	KW	BREAKER	AMPS	KW	BREAKER	AMPS	KW	BREAKER	AMPS	KW	BREAKER
208 - 240	3	50/60	1 - 1/0	L1, L2, L3, G	78.8 - 90.9	28.4 - 37.8	80 - 90	98.8 - 114	33.2 - 44.2	100 - 125	81.3 - 93.8	28.9 - 38.5	90 - 100	101.3 - 116.9	33.7 - 44.9	110 - 125
380 - 415	3	50	4 - 3	L1, L2, L3, N, G	48.2 - 52.5	32.3 - 37.8	63	60.5 - 65.8	37.1 - 44.2	63 - 80	50.9 - 55.4	32.8 - 38.5	63	63.1 - 68.7	37.7 - 44.9	100
440 - 480	3*	60	6 - 4	L1, L2, L3, G	41.7 - 45.5	32.4 - 37.8	50	52.2 - 57	37.2 - 44.2	60	43 - 46.9	32.9 - 38.5	50	53.6 - 58.5	37.8 - 44.9	60

*ELECTRICAL SERVICE CHARGE APPLIES

**NO-COST OPTION ON ELECTRIC MODELS

WEIGHT		SHIP DIMENSIONS		PAN CAPACITY			
NET	905 lbs est	411 kg	(L x W x H) 56" x 45" x 87"	FULL-SIZE:	20" x 12" x 2-1/2"	Twenty (20)	PRODUCT MAXIMUM: 240 lb (109 kg)
SHIP	955 lbs*	433 kg*	(1422 x 1143 x 2210mm)*	GN 1/1:	530 x 325 x 65mm	Twenty (20)	VOLUME MAXIMUM: 150 quarts (190 liters)
*DOMESTIC GROUND SHIPPING INFORMATION. CONTACT FACTORY FOR EXPORT WEIGHT AND DIMENSIONS.				*HALF-SIZE SHEET:	18" x 26" x 1"	Twenty (20)	*ADDITIONAL WIRE SHELVES REQUIRED FOR MAXIMUM CAPACITY
				*ON WIRE SHELVES ONLY			

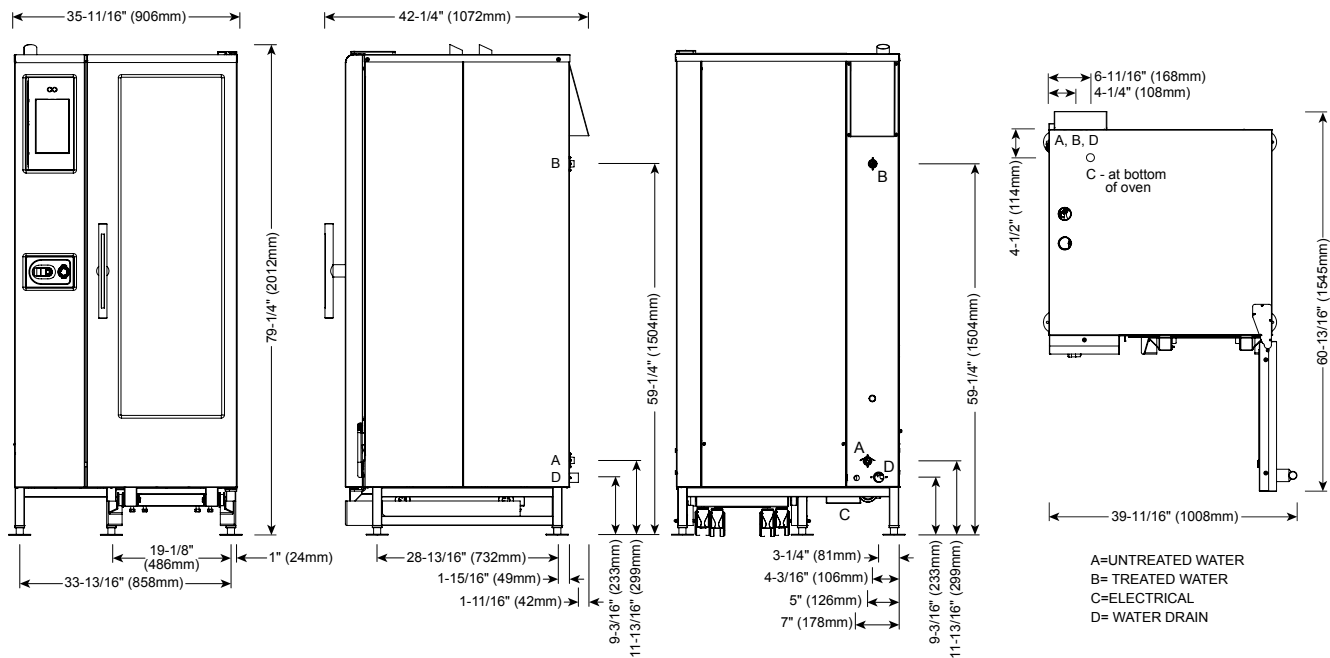

A=UNTREATED WATER
B= TREATED WATER
C=ELECTRICAL
D= WATER DRAIN



DIMENSIONS: H x W x D
EXTERIOR: 79-1/4" x 35-11/16" x 42-1/4" (2012mm x 906mm x 1072mm)
EXTERIOR WITH RECESSED DOOR: 79-1/4" x 39-11/16" x 42-1/4" (2012mm x 1008mm x 1072mm)
INTERIOR: 60-7/16" x 16-1/4" x 28-1/16" (1535mm x 411mm x 712mm)

WATER REQUIREMENTS
TWO (2) COLD WATER INLETS - DRINKING QUALITY
ONE (1) TREATED WATER INLET: 3/4" NPT* * Can manifold off of one 3/4" line.
ONE (1) UNTREATED WATER INLET: 3/4" NPT*
LINE PRESSURE: 30 to 90 psi 2.1 to 6.3 bar
WATER DRAIN: 1-1/2" (40mm) CONNECTION WITH A 2" MINIMUM AIR GAP INSTALLED AS CLOSE TO THE OVEN AS POSSIBLE. MATERIALS MUST WITHSTAND TEMPERATURES UP TO 200°F (93°C).
CLEARANCE REQUIREMENTS
LEFT: 0" (0mm) 18" (457mm) FOR SERVICE ACCESS
RIGHT: 0" (0mm) NON-COMBUSTIBLE SURFACES 2" (51mm) COMBUSTIBLE SURFACES
TOP: 20" (508mm) FOR AIR MOVEMENT
BACK: 4" (102mm) BOTTOM: 5-1/8" (130mm) FOR LEGS, AIR INTAKE
INSTALLATION REQUIREMENTS
• Oven must be installed level. • Hood installation is required.
• Water supply shut-off valve and back-flow preventer when required by local code.

WATER QUALITY STANDARDS
It is the sole responsibility of the owner/operator/purchaser of this equipment to verify that the incoming water supply is comprehensively tested and if required, a means of "water treatment" provided that would meet compliance requirements with the published water quality standards published below. Non-compliance with these minimum standards will potentially damage this equipment and/or components and VOID the original equipment manufacturer's warranty. Alto-Shaam recommends using OptiPure® [www.optipurewater.com] products to properly treat your water.
Contaminant Inlet Water Requirements
Free Chlorine Less than 0.1 ppm (mg/L)
Hardness 30-70 ppm
Chloride Less than 30 ppm (mg/L)
pH 7.0 to 8.5
Silica Less than 12 ppm (mg/L)
Total Dissolved Solids (tds) 50-125 ppm

ELECTRICAL (NO CORD, NO PLUG, DEDICATED CIRCUIT REQUIRED) DO NOT CONNECT TO G.F.I. OUTLET										
MODEL	VOLTAGE	PH	HZ	AMPS	kW	BREAKER	AWG	CONNECTION		
CTC20-10E	208 – 240	3	50/60	78.8 – 90.9	28.4 – 37.8	80-90	1 – 1/0	L1, L2, L3, G		
	380 – 415	3	50	48.2 – 52.5	32.3 – 37.8	63	4 – 3	L1, L2, L3, N, G		
	440 – 480	3*	60	41.7 – 45.5	32.4 – 37.8	50	6 – 4	L1, L2, L3, G		

*ELECTRICAL SERVICE CHARGE APPLIES

WEIGHT	SHIP DIMENSIONS	PAN CAPACITY	
NET 905 lbs est 411 kg	(L x W x H) 56" x 45" x 87"*	FULL-SIZE: 20" x 12" x 2-1/2" Twenty (20)	PRODUCT MAXIMUM: 240 lb (109 kg)
SHIP 955 lbs* 433 kg*	(1422 x 1143 x 2210mm)*	GN 1/1: 530 x 325 x 65mm Twenty (20)	VOLUME MAXIMUM: 150 quarts (190 liters)
*DOMESTIC GROUND SHIPPING INFORMATION. CONTACT FACTORY FOR EXPORT WEIGHT AND DIMENSIONS.		*HALF-SIZE SHEET: 18" x 13" x 1" Twenty (20)	*ADDITIONAL WIRE SHELVES REQUIRED FOR MAXIMUM CAPACITY
		*ON WIRE SHELVES ONLY	

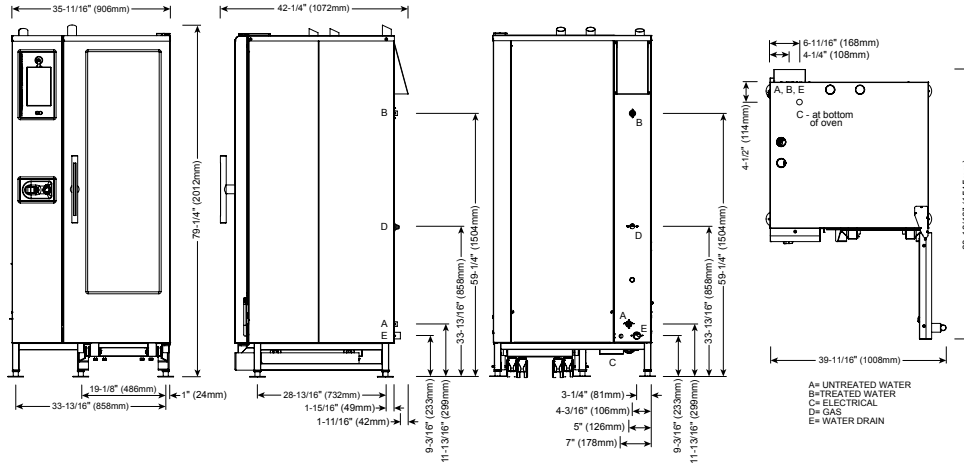

DIMENSIONS: H x W x D
EXTERIOR: 79-1/4" x 35-11/16" x 42-1/4" (2012mm x 906mm x 1072mm)
EXTERIOR WITH RECESSED DOOR: 79-1/4" x 39-11/16" x 42-1/4" (2012mm x 1008mm x 1072mm)
INTERIOR: 60-7/16" x 16-1/4" x 28-1/16" (1535mm x 411mm x 712mm)

WATER REQUIREMENTS	
TWO (2) COLD WATER INLETS - DRINKING QUALITY	
ONE (1) TREATED WATER INLET: 3/4" NPT*	* Can manifold off of one 3/4" line.
ONE (1) UNTREATED WATER INLET: 3/4" NPT*	
LINE PRESSURE: 30 to 90 psi	2.1 to 6.3 bar
WATER DRAIN: 1-1/2" (40mm) CONNECTION WITH A 2" MINIMUM AIR GAP INSTALLED AS CLOSE TO THE OVEN AS POSSIBLE. MATERIALS MUST WITHSTAND TEMPERATURES UP TO 200°F (93°C).	
CLEARANCE REQUIREMENTS	
LEFT: 0" (0mm)	18" (457mm) FOR SERVICE ACCESS
RIGHT: 0" (0mm)	NON-COMBUSTIBLE SURFACES 2" (51mm) COMBUSTIBLE SURFACES
TOP: 20" (508mm) FOR AIR MOVEMENT	
BACK: 4" (102mm)	BOTTOM: 5-1/8" (130mm) FOR LEGS, AIR INTAKE
INSTALLATION REQUIREMENTS	
• Oven must be installed level. • Hood installation is required.	
• Water supply shut-off valve and back-flow preventer when required by local code.	

WATER QUALITY STANDARDS	
It is the sole responsibility of the owner/operator/purchaser of this equipment to verify that the incoming water supply is comprehensively tested and if required, a means of "water treatment" provided that would meet compliance requirements with the published water quality standards published below. Non-compliance with these minimum standards will potentially damage this equipment and/or components and VOID the original equipment manufacturer's warranty. Alto-Shaam recommends using OptiPure® [www.optipurewater.com] products to properly treat your water.	
Contaminant	Inlet Water Requirements
Free Chlorine	Less than 0.1 ppm (mg/L)
Hardness	30-70 ppm
Chloride	Less than 30 ppm (mg/L)
pH	7.0 to 8.5
Silica	Less than 12 ppm (mg/L)
Total Dissolved Solids (tds)	50-125 ppm

GAS REQUIREMENTS (GAS TYPE MUST BE SPECIFIED ON ORDER)	
HOOK-UP: 3/4" NPT Alternate burner orifice is required for installation sites at elevations of 2,000 feet (610m) above sea level	

RATED THERMAL LOAD		CONNECTED PRESSURE			
NORTH AMERICA	INTERNATIONAL	NORTH AMERICA		INTERNATIONAL	
Natural Gas/Propane	G20, G25, G31	Natural Gas	Propane	G20	20mbar
Gross Heating Value (HHV) 160,000 Btu / hr	Net Heating Value (LHV) 42.5 kW	Minimum: 5.5" W.C. Maximum: 14" W.C.	Minimum: 9" W.C. Maximum: 14" W.C.	G25	20mbar
				G31	30mbar

ELECTRICAL - CTP20-10G (DEDICATED CIRCUIT REQUIRED) DO NOT CONNECT TO A G.F.I. OUTLET									WITH COMBISMOKER® OPTION			
VOLTAGE	PH	HZ	AWG	CONNECTION no cord, no plug	AMPS	BREAKER	kW	CONNECTION no cord, no plug	AMPS	BREAKER	kW	
↻	120	1	60	14	L1, N, G	13.6	20	1.7	L1, N, G	15.8	20	2.32
↻	208 - 240	1+	50/60	14	L1, L2/N, G	9.6 - 8.4	15	2.0	L1, L2/N, G	12.1 - 11.3	15	2.5 - 2.7
↻	208 - 240	3	50/60	14	L1, L2, L3, G	9.6 - 8.4	15	2.0	L1, L2, L3, G	12.1 - 11.3	15	2.5 - 2.7
↻	380 - 415	3	50	14	L1, L2, L3, N, G	9.2 - 8.4	15	2.0	L1, L2, L3, N, G	11.8 - 11.3	15	2.6 - 2.7

↻ NORTH AMERICA VOLTAGE CHOICE		↻ INTERNATIONAL VOLTAGE CHOICE		*ELECTRICAL SERVICE CHARGE APPLIES	
WEIGHT	SHIP DIMENSIONS	PAN CAPACITY			
NET 905 lbs est 411 kg	(L x W x H) 56" x 45" x 87"	FULL-SIZE:	20" x 12" x 2-1/2"	Twenty (20)	PRODUCT MAXIMUM: 240 lb (109 kg)
SHIP 955 lbs* 433 kg*	(1422 x 1143 x 2210mm)*	GN 1/1:	530 x 325 x 65mm	Twenty (20)	VOLUME MAXIMUM: 150 quarts (190 liters)
*DOMESTIC GROUND SHIPPING INFORMATION. CONTACT FACTORY FOR EXPORT WEIGHT AND DIMENSIONS.		*HALF-SIZE SHEET:	18" x 13" x 1"	Twenty (20)	*ADDITIONAL WIRE SHELVES REQUIRED FOR MAXIMUM CAPACITY
		*ON WIRE SHELVES ONLY			

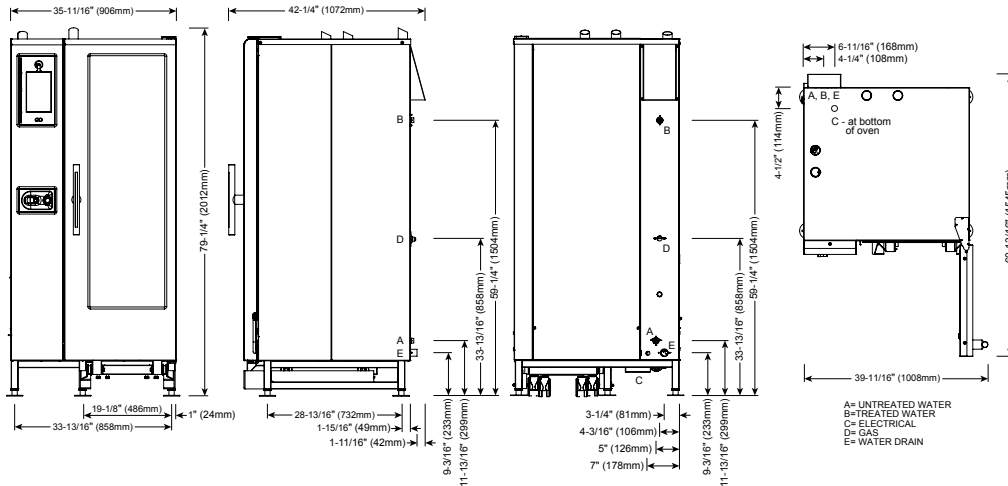

DIMENSIONS: H x W x D
EXTERIOR: 79-1/4" x 35-11/16" x 42-1/4" (2012mm x 906mm x 1072mm)
EXTERIOR WITH RECESSED DOOR: 79-1/4" x 39-11/16" x 42-1/4" (2012mm x 1008mm x 1072mm)
INTERIOR: 60-7/16" x 16-1/4" x 28-1/16" (1535mm x 411mm x 712mm)



IP X5



WATER REQUIREMENTS
TWO (2) COLD WATER INLETS - DRINKING QUALITY
ONE (1) TREATED WATER INLET: 3/4" NPT* * Can manifold off of one 3/4" line.
ONE (1) UNTREATED WATER INLET: 3/4" NPT*
LINE PRESSURE: 30 to 90 psi 2.1 to 6.3 bar
WATER DRAIN: 1-1/2" (40mm) CONNECTION WITH A 2" MINIMUM AIR GAP INSTALLED AS CLOSE TO THE OVEN AS POSSIBLE. MATERIALS MUST WITHSTAND TEMPERATURES UP TO 200°F (93°C).
CLEARANCE REQUIREMENTS
LEFT: 0" (0mm) 18" (457mm) FOR SERVICE ACCESS
RIGHT: 0" (0mm) NON-COMBUSTIBLE SURFACES 2" (51mm) COMBUSTIBLE SURFACES
TOP: 20" (508mm) FOR AIR MOVEMENT
BACK: 4" (102mm) BOTTOM: 5-1/8" (130mm) FOR LEGS, AIR INTAKE
INSTALLATION REQUIREMENTS
• Oven must be installed level. • Hood installation is required.
• Water supply shut-off valve and back-flow preventer when required by local code.

WATER QUALITY STANDARDS
It is the sole responsibility of the owner/operator/purchaser of this equipment to verify that the incoming water supply is comprehensively tested and if required, a means of "water treatment" provided that would meet compliance requirements with the published water quality standards published below. Non-compliance with these minimum standards will potentially damage this equipment and/or components and VOID the original equipment manufacturer's warranty. Alto-Shaam recommends using OptiPure® [www.optipurewater.com] products to properly treat your water.
Contaminant Inlet Water Requirements
Free Chlorine Less than 0.1 ppm (mg/L)
Hardness 30-70 ppm
Chloride Less than 30 ppm (mg/L)
pH 7.0 to 8.5
Silica Less than 12 ppm (mg/L)
Total Dissolved Solids (tds) 50-125 ppm

GAS REQUIREMENTS (GAS TYPE MUST BE SPECIFIED ON ORDER)			
HOOK-UP: 3/4" NPT Alternate burner orifice is required for installation sites at elevations of 2,000 feet (610m) above sea level			
RATED THERMAL LOAD	CONNECTED PRESSURE		
NORTH AMERICA	INTERNATIONAL	NORTH AMERICA	INTERNATIONAL
Natural Gas/Propane	G20, G25, G31	Natural Gas	Propane
Gross Heating Value (HHV)	Net Heating Value (LHV)	Minimum: 5.5" W.C.	Minimum: 9" W.C.
140,000 Btu / hr	37.0 kW	Maximum: 14" W.C.	Maximum: 14" W.C.

ELECTRICAL - CTC20-10G (DEDICATED CIRCUIT REQUIRED) DO NOT CONNECT TO A G.F.I. OUTLET								
	VOLTAGE	PH	HZ	AWG	CONNECTION	AMPS	BREAKER	kW
↻	120	1	60	12	L1, N, G - no cord, no plug	13.0	20	1.7
↻	208 - 240	3	50/60	14	L1, L2, L3, G - no cord, no plug	9.6 - 8.4	15	2.0
↻	380 - 415	3	50	14	L1, L2, L3, N, G - no cord, no plug	9.2 - 8.4	15	2.0

↻ NORTH AMERICA VOLTAGE CHOICE ↻ INTERNATIONAL VOLTAGE CHOICE

WEIGHT	SHIP DIMENSIONS	PAN CAPACITY	
NET 905 lbs est 411 kg	(L x W x H) 56" x 45" x 87"*	FULL-SIZE: 20" x 12" x 2-1/2" Twenty (20)	PRODUCT MAXIMUM: 240 lb (109 kg)
SHIP 955 lbs* 433 kg*	(1422 x 1143 x 2210mm)*	GN 1/1: 530 x 325 x 65mm Twenty (20)	VOLUME MAXIMUM: 150 quarts (190 liters)
*DOMESTIC GROUND SHIPPING INFORMATION. CONTACT FACTORY FOR EXPORT WEIGHT AND DIMENSIONS.		*HALF-SIZE SHEET: 18" x 13" x 1" Twenty (20)	*ADDITIONAL WIRE SHELVES REQUIRED FOR MAXIMUM CAPACITY
		*ON WIRE SHELVES ONLY	

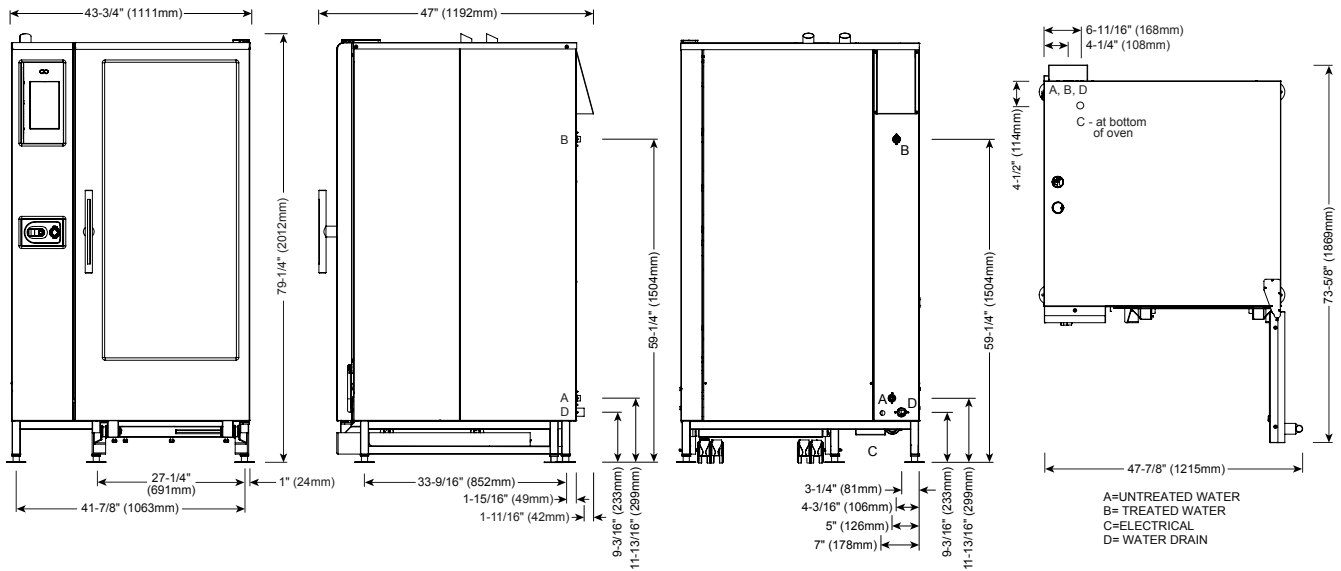

IP X5



DIMENSIONS: H x W x D	
EXTERIOR:	79-1/4" x 43-3/4" x 47" (2012mm x 1111mm x 1192mm)
EXTERIOR WITH RECESSED DOOR:	79-1/4" x 47-3/4" x 47" (2012mm x 1213mm x 1192mm)
INTERIOR:	60-7/16" x 24-1/4" x 32-3/4" (1535mm x 616mm x 832mm)

WATER REQUIREMENTS

TWO (2) COLD WATER INLETS - DRINKING QUALITY
ONE (1) TREATED WATER INLET: 3/4" NPT* * Can manifold off of one 3/4" line.
ONE (1) UNTREATED WATER INLET: 3/4" NPT*
LINE PRESSURE: 30 to 90 psi 2.1 to 6.3 bar
WATER DRAIN: 1-1/2" (40mm) CONNECTION WITH A 2" MINIMUM AIR GAP INSTALLED AS CLOSE TO THE OVEN AS POSSIBLE. MATERIALS MUST WITHSTAND TEMPERATURES UP TO 200°F (93°C).

CLEARANCE REQUIREMENTS

LEFT: 0" (0mm) 18" (457mm) FOR SERVICE ACCESS
RIGHT: 0" (0mm) NON-COMBUSTIBLE SURFACES 2" (51mm) COMBUSTIBLE SURFACES
TOP: 20" (508mm) FOR AIR MOVEMENT
BACK: 4" (102mm) **BOTTOM:** 5-1/8" (130mm) FOR LEGS, AIR INTAKE

INSTALLATION REQUIREMENTS

- Oven must be installed level.
- Hood installation is required.
- Water supply shut-off valve and back-flow preventer when required by local code.

WATER QUALITY STANDARDS

It is the sole responsibility of the owner/operator/purchaser of this equipment to verify that the incoming water supply is comprehensively tested and if required, a means of "water treatment" provided that would meet compliance requirements with the published water quality standards published below. Non-compliance with these minimum standards will potentially damage this equipment and/or components and VOID the original equipment manufacturer's warranty. Alto-Shaam recommends using OptiPure® [www.optipurewater.com] products to properly treat your water.

Contaminant	Inlet Water Requirements
Free Chlorine	Less than 0.1 ppm (mg/L)
Hardness	30-70 ppm
Chloride	Less than 30 ppm (mg/L)
pH	7.0 to 8.5
Silica	Less than 12 ppm (mg/L)
Total Dissolved Solids (tds)	50-125 ppm

ELECTRICAL - CTP20-20E (NO CORD, NO PLUG, DEDICATED CIRCUIT REQUIRED) DO NOT CONNECT TO A G.F.I. OUTLET

										WITH COMBISMOKER® OPTION											
										ECO STANDARD			**PROpower™ OPTION			ECO STANDARD			**PROpower™ OPTION		
VOLTAGE	PH	HZ	AWG	CONNECTION	AMPS	kW	BREAKER	AMPS	kW	BREAKER	AMPS	kW	BREAKER	AMPS	kW	BREAKER	AMPS	kW	BREAKER		
208-240	3	50/60	8	L1, L2, L3, G	137.6-158.8	49.6-66	150-175	172-198.5	57.8-77	175-200	140.1-161.6	50.1-66.7	150-175	174.5-201.3	58.4-77.7	200-225					
380-415	3	50	8	L1, L2, L3, N, G	84.2-91.7	56.4-66	100	105.3-114.6	64.7-77	125	86.9-94.5	56.9-66.7	100	107.9-117.5	65.3-77.7	150					
440-480	3*	60	10-8	L1, L2, L3, G	72.7-79.4	56.5-66	80	90.9-99.2	64.8-77	100	74.1-80.8	57.1-66.7	80-90	92.3-100.7	65.4-77.7	100					

*ELECTRICAL SERVICE CHARGE APPLIES

**NO-COST OPTION ON ELECTRIC MODELS

WEIGHT			SHIP DIMENSIONS			PAN CAPACITY			
NET	1100 lbs est	499 kg	(L x W x H)	53" x 53" x 87"	FULL-SIZE:	20" x 12" x 2-1/2"	Forty (40)	PRODUCT MAXIMUM:	480 lb (218 kg)
SHIP	1150 lbs*	522 kg*		(1346 x 1346 x 2210mm)*	*ON WIRE SHELVES ONLY	GN 1/1: 530 x 325 x 65mm	Forty (40)	VOLUME MAXIMUM:	300 quarts (380 liters)
						GN 2/1: 650 x 530 x 65mm	Twenty (20)	*ADDITIONAL WIRE SHELVES REQUIRED FOR MAXIMUM CAPACITY	
						*FULL-SIZE SHEET: 18" x 26" x 1"	Twenty (20)		

*DOMESTIC GROUND SHIPPING INFORMATION. CONTACT FACTORY FOR EXPORT WEIGHT AND DIMENSIONS.

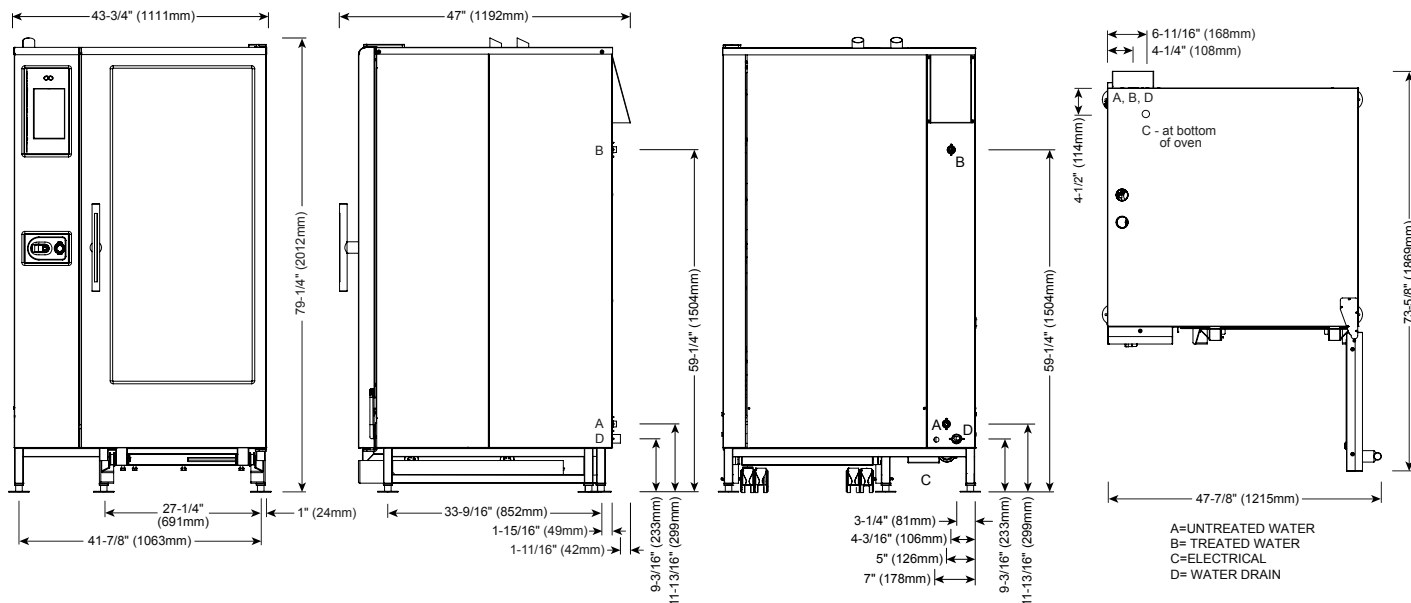

DIMENSIONS: H x W x D

EXTERIOR: 79-1/4" x 43-3/4" x 47" (2012mm x 1111mm x 1192mm)

EXTERIOR WITH RECESSED DOOR: 79-1/4" x 47-3/4" x 47" (2012mm x 1213mm x 1192mm)

INTERIOR: 60-7/16" x 24-1/4" x 32-3/4" (1535mm x 616mm x 832mm)

WATER REQUIREMENTS

TWO (2) COLD WATER INLETS - DRINKING QUALITY
ONE (1) TREATED WATER INLET: 3/4" NPT* * Can manifold off of one
ONE (1) UNTREATED WATER INLET: 3/4" NPT* 3/4" line.
LINE PRESSURE: 30 to 90 psi 2.1 to 6.3 bar
WATER DRAIN: 1-1/2" (40mm) CONNECTION WITH A 2" MINIMUM AIR GAP INSTALLED AS CLOSE TO THE OVEN AS POSSIBLE. MATERIALS MUST WITHSTAND TEMPERATURES UP TO 200°F (93°C).

CLEARANCE REQUIREMENTS

LEFT: 0" (0mm) 18" (457mm) FOR SERVICE ACCESS
RIGHT: 0" (0mm) NON-COMBUSTIBLE SURFACES 2" (51mm) COMBUSTIBLE SURFACES
TOP: 20" (508mm) FOR AIR MOVEMENT
BACK: 4" (102mm) **BOTTOM:** 5-1/8" (130mm) FOR LEGS, AIR INTAKE

INSTALLATION REQUIREMENTS

- Oven must be installed level. Hood installation is required.
- Water supply shut-off valve and back-flow preventer when required by local code.

WATER QUALITY STANDARDS

It is the sole responsibility of the owner/operator/purchaser of this equipment to verify that the incoming water supply is comprehensively tested and if required, a means of "water treatment" provided that would meet compliance requirements with the published water quality standards published below. Non-compliance with these minimum standards will potentially damage this equipment and/or components and VOID the original equipment manufacturer's warranty. Alto-Shaam recommends using OptiPure® [www.optipurewater.com] products to properly treat your water.

Contaminant	Inlet Water Requirements
Free Chlorine	Less than 0.1 ppm (mg/L)
Hardness	30-70 ppm
Chloride	Less than 30 ppm (mg/L)
pH	7.0 to 8.5
Silica	Less than 12 ppm (mg/L)
Total Dissolved Solids (tds)	50-125 ppm

ELECTRICAL (NO CORD, NO PLUG, DEDICATED CIRCUIT REQUIRED) DO NOT CONNECT TO A G.F.I. OUTLET

MODEL	VOLTAGE	PH	HZ	AMPS	kW	BREAKER	AWG	CONNECTION
CTC20-20E	208 – 240	3	50/60	137.6 – 158.8	49.6 – 66	150-175	4/0	L1, L2, L3, G
	380 – 415	3	50	84.2 – 91.7	56.4 – 66	100	1 – 1/0	L1, L2, L3, N, G
	440 – 480	3*	60	72.7 – 79.4	56.5 – 66	80	2 – 1	L1, L2, L3, G

*ELECTRICAL SERVICE CHARGE APPLIES

WEIGHT		SHIP DIMENSIONS		PAN CAPACITY		PRODUCT MAXIMUM: 480 lb (218 kg)	
NET	1100 lbs est 499 kg	(L x W x H)	53" x 53" x 87"	FULL-SIZE:	20" x 12" x 2-1/2"	Forty (40)	VOLUME MAXIMUM: 300 quarts (380 liters)
SHIP	1150 lbs* 522 kg*	(1346 x 1346 x 2210mm)*		*ON WIRE	GN 1/1: 530 x 325 x 65mm	Forty (40)	
*DOMESTIC GROUND SHIPPING INFORMATION. CONTACT FACTORY FOR EXPORT WEIGHT AND DIMENSIONS.				SHELVES ONLY	GN 2/1: 650 x 530 x 65mm	Twenty (20)	*ADDITIONAL WIRE SHELVES REQUIRED FOR MAXIMUM CAPACITY
				*FULL-SIZE SHEET:	18" x 26" x 1"	Twenty (20)	

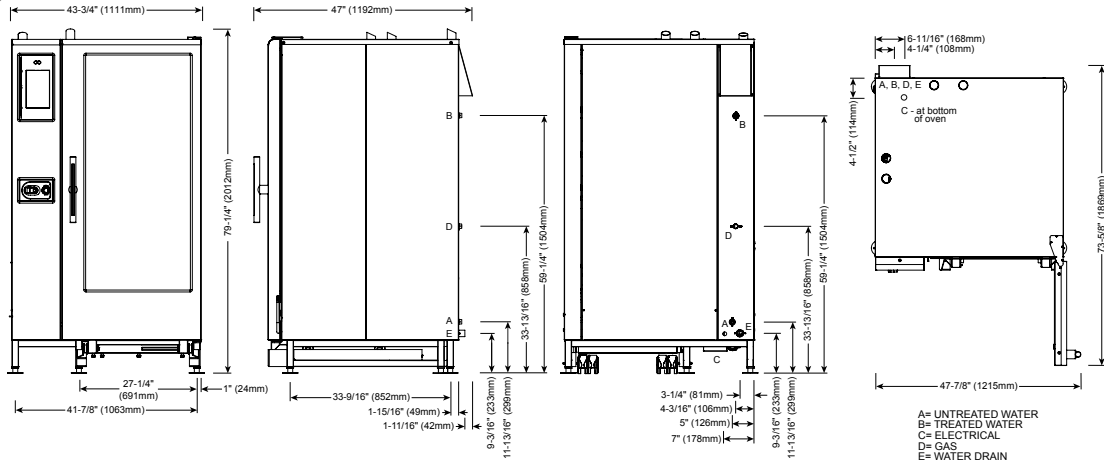

DIMENSIONS: H x W x D
EXTERIOR: 79-1/4" x 43-3/4" x 47" (2012mm x 1111mm x 1192mm)
EXTERIOR WITH RECESSED DOOR: 79-1/4" x 47-3/4" x 47" (2012mm x 1213mm x 1192mm)
INTERIOR: 60-7/16" x 24-1/4" x 32-3/4" (1535mm x 616mm x 832mm)

WATER REQUIREMENTS
TWO (2) COLD WATER INLETS - DRINKING QUALITY
ONE (1) TREATED WATER INLET: 3/4" NPT* * Can manifold off of one 3/4" line.
ONE (1) UNTREATED WATER INLET: 3/4" NPT*
LINE PRESSURE: 30 to 90 psi 2.1 to 6.3 bar
WATER DRAIN: 1-1/2" (40mm) CONNECTION WITH A 2" MINIMUM AIR GAP INSTALLED AS CLOSE TO THE OVEN AS POSSIBLE. MATERIALS MUST WITHSTAND TEMPERATURES UP TO 200°F (93°C).
CLEARANCE REQUIREMENTS
LEFT: 0" (0mm) 18" (457mm) FOR SERVICE ACCESS
RIGHT: 0" (0mm) NON-COMBUSTIBLE SURFACES 2" (51mm) COMBUSTIBLE SURFACES
TOP: 20" (508mm) FOR AIR MOVEMENT
BACK: 4" (102mm) BOTTOM: 5-1/8" (130mm) FOR LEGS, AIR INTAKE
INSTALLATION REQUIREMENTS
• Oven must be installed level. • Hood installation is required.
• Water supply shut-off valve and back-flow preventer when required by local code.

WATER QUALITY STANDARDS
It is the sole responsibility of the owner/operator/purchaser of this equipment to verify that the incoming water supply is comprehensively tested and if required, a means of "water treatment" provided that would meet compliance requirements with the published water quality standards published below. Non-compliance with these minimum standards will potentially damage this equipment and/or components and VOID the original equipment manufacturer's warranty. Alto-Shaam recommends using OptiPure® [www.optipurewater.com] products to properly treat your water.
Contaminant Inlet Water Requirements
Free Chlorine Less than 0.1 ppm (mg/L)
Hardness 30-70 ppm
Chloride Less than 30 ppm (mg/L)
pH 7.0 to 8.5
Silica Less than 12 ppm (mg/L)
Total Dissolved Solids (tds) 50-125 ppm

GAS REQUIREMENTS (GAS TYPE MUST BE SPECIFIED ON ORDER)
HOOK-UP: 3/4" NPT Alternate burner orifice is required for installation sites at elevations of 2,000 feet (610m) above sea level

RATED THERMAL LOAD		CONNECTED PRESSURE			
NORTH AMERICA	INTERNATIONAL	NORTH AMERICA		INTERNATIONAL	
Natural Gas/Propane	G20, G25, G31	Natural Gas	Propane	G20	20mbar
Gross Heating Value (HHV) 266,000 Btu / hr	Net Heating Value (LHV) 72.0 kW	Minimum: 5.5" W.C. Maximum: 14" W.C.	Minimum: 9" W.C. Maximum: 14" W.C.	G25	20mbar
				G31	30mbar

ELECTRICAL - CTP20-20G (DEDICATED CIRCUIT REQUIRED) DO NOT CONNECT TO A G.F.I. OUTLET									WITH COMBISMOKER® OPTION			
VOLTAGE	PH	HZ	AWG	CONNECTION no cord, no plug	AMPS	BREAKER	KW	CONNECTION no cord, no plug	AMPS	BREAKER	KW	
120	1	60	14	L1, N, G	13.6	20	1.7	L1, N, G	15.8	20	2.32	
208 - 240	1*	50/60	14	L1, L2/N, G	9.6 - 8.4	15	2.0	L1, L2/N, G	12.1 - 11.3	15	2.5 - 2.7	
208 - 240	3	50/60	14	L1, L2, L3, G	9.6 - 8.4	15	2.0	L1, L2, L3, G	12.1 - 11.3	15	2.5 - 2.7	
380 - 415	3	50	14	L1, L2, L3, N, G	9.2 - 8.4	15	2.0	L1, L2, L3, N, G	11.8 - 11.3	15	2.6 - 2.7	

◀ NORTH AMERICA VOLTAGE CHOICE		▶ INTERNATIONAL VOLTAGE CHOICE		*ELECTRICAL SERVICE CHARGE APPLIES	
WEIGHT	SHIP DIMENSIONS	PAN CAPACITY			
NET 1100 lbs est 499 kg	(L x W x H) 53" x 53" x 87"*	FULL-SIZE:	20" x 12" x 2-1/2"	Forty (40)	PRODUCT MAXIMUM: 480 lb (218 kg)
SHIP 1150 lbs* 522 kg*	(1346 x 1346 x 2210mm)*	*ON WIRE	GN 1/1: 530 x 325 x 65mm	Forty (40)	VOLUME MAXIMUM: 300 quarts (380 liters)
*DOMESTIC GROUND SHIPPING INFORMATION. CONTACT FACTORY FOR EXPORT WEIGHT AND DIMENSIONS.		SHELVES ONLY	GN 2/1: 650 x 530 x 65mm	Twenty (20)	*ADDITIONAL WIRE SHELVES REQUIRED FOR MAXIMUM CAPACITY
		*FULL-SIZE SHEET:	18" x 26" x 1"	Twenty (20)	

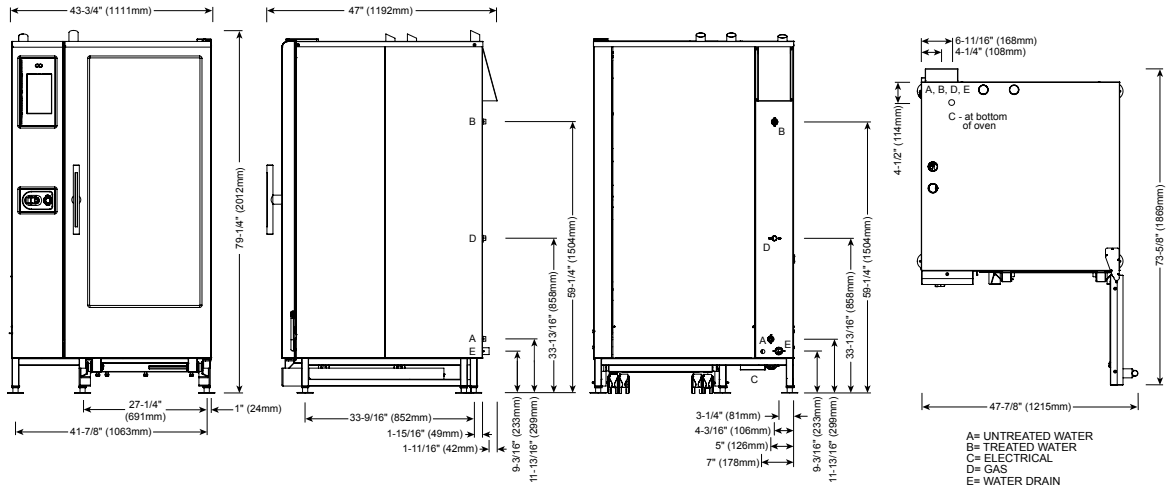

A= UNTREATED WATER
 B= TREATED WATER
 C= ELECTRICAL
 D= GAS
 E= WATER DRAIN

DIMENSIONS: H x W x D	
EXTERIOR:	79-1/4" x 43-3/4" x 47" (2012mm x 1111mm x 1192mm)
EXTERIOR WITH RECESSED DOOR:	79-1/4" x 47-3/4" x 47" (2012mm x 1213mm x 1192mm)
INTERIOR:	60-7/16" x 24-1/4" x 32-3/4" (1535mm x 616mm x 832mm)



WATER REQUIREMENTS	
TWO (2) COLD WATER INLETS - DRINKING QUALITY	
ONE (1) TREATED WATER INLET:	3/4" NPT* * Can manifold off of one
ONE (1) UNTREATED WATER INLET:	3/4" NPT* 3/4" line.
LINE PRESSURE:	30 to 90 psi 2.1 to 6.3 bar
WATER DRAIN: 1-1/2" (40mm) CONNECTION WITH A 2" MINIMUM AIR GAP INSTALLED AS CLOSE TO THE OVEN AS POSSIBLE. MATERIALS MUST WITHSTAND TEMPERATURES UP TO 200°F (93°C).	
CLEARANCE REQUIREMENTS	
LEFT:	0" (0mm) 18" (457mm) FOR SERVICE ACCESS
RIGHT:	0" (0mm) NON-COMBUSTIBLE SURFACES 2" (51mm) COMBUSTIBLE SURFACES
TOP:	20" (508mm) FOR AIR MOVEMENT
BACK:	4" (102mm) BOTTOM: 5-1/8" (130mm) FOR LEGS, AIR INTAKE
INSTALLATION REQUIREMENTS	
• Oven must be installed level. • Hood installation is required.	
• Water supply shut-off valve and back-flow preventer when required by local code.	

WATER QUALITY STANDARDS	
It is the sole responsibility of the owner/operator/purchaser of this equipment to verify that the incoming water supply is comprehensively tested and if required, a means of "water treatment" provided that would meet compliance requirements with the published water quality standards published below. Non-compliance with these minimum standards will potentially damage this equipment and/or components and VOID the original equipment manufacturer's warranty. Alto-Shaam recommends using OptiPure® [www.optipurewater.com] products to properly treat your water.	
Contaminant	Inlet Water Requirements
Free Chlorine	Less than 0.1 ppm (mg/L)
Hardness	30-70 ppm
Chloride	Less than 30 ppm (mg/L)
pH	7.0 to 8.5
Silica	Less than 12 ppm (mg/L)
Total Dissolved Solids (tds)	50-125 ppm

GAS REQUIREMENTS (GAS TYPE MUST BE SPECIFIED ON ORDER)

HOOK-UP: 3/4" NPT Alternate burner orifice is required for installation sites at elevations of 2,000 feet (610m) above sea level

RATED THERMAL LOAD		CONNECTED PRESSURE			
NORTH AMERICA	INTERNATIONAL	NORTH AMERICA		INTERNATIONAL	
Natural Gas/Propane	G20, G25, G31	Natural Gas	Propane	G20	20mbar
Gross Heating Value (HHV)	Net Heating Value (LHV)	Minimum: 5.5" W.C.	Minimum: 9" W.C.	G25	20mbar
242,000 Btu / hr	64.5 kW	Maximum: 14" W.C.	Maximum: 14" W.C.	G31	30mbar

ELECTRICAL - CTC20-20G (DEDICATED CIRCUIT REQUIRED) DO NOT CONNECT TO A G.F.I. OUTLET								
	VOLTAGE	PH	HZ	AWG	CONNECTION	AMPS	BREAKER	KW
↻	120	1	60	12	L1, N, G - no cord, no plug	13.0	20	1.7
↻	208 - 240	3	50/60	14	L1, L2, L3, G - no cord, no plug	9.6 - 8.4	15	2.0
↻	380 - 415	3	50	14	L1, L2, L3, N, G - no cord, no plug	9.2 - 8.4	15	2.0

↻ NORTH AMERICA VOLTAGE CHOICE ↻ INTERNATIONAL VOLTAGE CHOICE

WEIGHT	SHIP DIMENSIONS	PAN CAPACITY		
NET 1100 lbs est 499 kg	(L x W x H) 53" x 53" x 87"	FULL-SIZE:	20" x 12" x 2-1/2"	Forty (40)
SHIP 1150 lbs* 522 kg*	(1346 x 1346 x 2210mm)*	*ON WIRE	GN 1/1:	530 x 325 x 65mm
		SHELVES ONLY	GN 2/1:	650 x 530 x 65mm
		*FULL-SIZE SHEET:	18" x 26" x 1"	Twenty (20)
*DOMESTIC GROUND SHIPPING INFORMATION. CONTACT FACTORY FOR EXPORT WEIGHT AND DIMENSIONS.				PRODUCT MAXIMUM: 480 lb (218 kg)
				VOLUME MAXIMUM: 300 quarts (380 liters)
				*ADDITIONAL WIRE SHELVES REQUIRED FOR MAXIMUM CAPACITY

INSTALLATION

SITE INSTALLATION

CAUTION



THE APPLIANCE MUST REMAIN ON THE PALLET WHILE BEING MOVED TO THE INSTALLATION SITE BY FORK LIFT OR PALLET LIFT TRUCK.

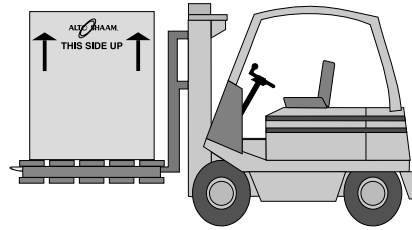

INSTALLATION

To insure proper operation, the installation of this oven must be completed by qualified technicians in accordance with the instructions provided in this manual. Failure to follow the instructions provided may result in damage to the oven, building, or cause personal injury to personnel.

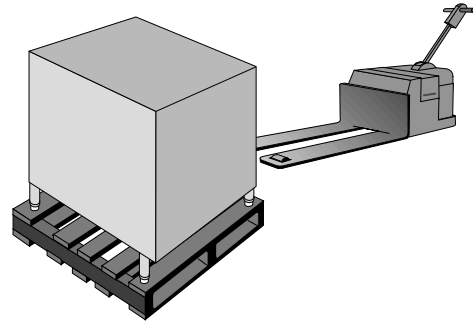

NOTE: Note dimensions required for doorways and aisles for access of the oven and pallet to the installation site. Transport the oven in an upright and level position only. Do not tilt the oven.

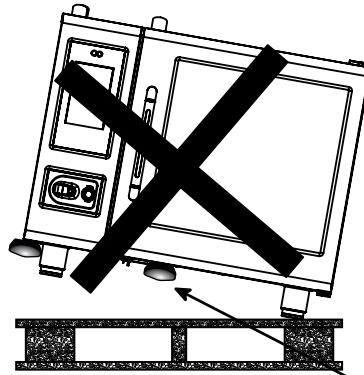

NOTE: To avoid equipment damage, observe attention label on oven for area to avoid with lifting fork.



LIFTING INSTRUCTIONS

Remove banding before lifting. **Lift the unit from the front only, never from the side.**

Adjust the forks so that they do not damage any of the components under the unit. **Note that the control side of the oven is the heaviest portion.** Lift the unit just high enough to remove the wooden pallet. Lower the unit as close to the floor as possible and no more than 2" (50mm) above the floor. Secure hoses and dangling cords to avoid tangling or damage. **When moving the unit, drive slowly, keep it low to the ground, and use extreme caution.**

DEPTH OF FORKS IS CRITICAL FOR UNITS EQUIPPED WITH GREASE COLLECTION TO AVOID DAMAGING THE PUMP

INSTALLATION

SITE INSTALLATION

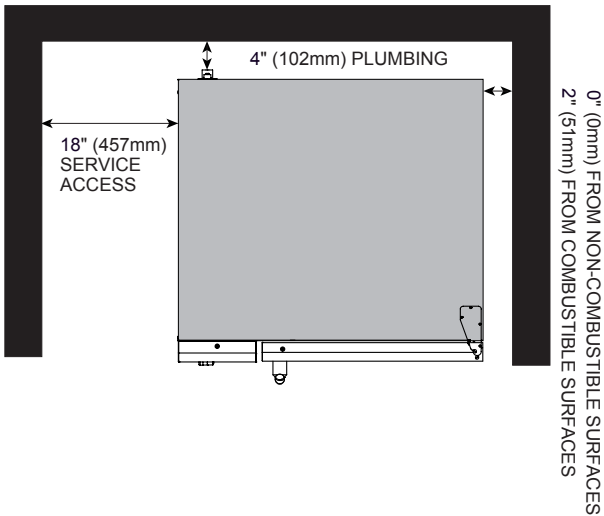

MINIMUM CLEARANCE REQUIREMENTS	
LEFT SIDE	0" (0mm) MINIMUM 18" (457mm) SERVICE ACCESS RECOMMENDED
RIGHT SIDE	0" (0mm) FROM NON-COMBUSTIBLE SURFACES 2" (51mm) FROM COMBUSTIBLE SURFACES
BACK	4" (102mm) FOR PLUMBING
TOP	20" (508mm) FOR AIR MOVEMENT
BOTTOM	5-1/8" (457mm) FOR LEGS AND UNOBSTRUCTED AIR INTAKE

NOTE: Clearance is needed for service access. A minimum distance of 18-inches (457mm) is strongly recommended. If adequate service clearance is not provided, it will be necessary to disconnect the gas, water, and drain to move the oven with a fork lift for service access. Charges in connection with inadequate service access is not covered under warranty.

POSITIONING ON SITE

Place the oven on a stable, non-combustible level horizontal surface. Use the adjustable feet to overcome an uneven floor and ensure that the unit is level.

It is strongly recommended that table top models be mounted on a factory supplied stand or a stand that is stable, open, and level. The adjustable oven legs should be extended beyond the depth of the positioning ring to allow for leveling after the oven has been placed on the stand. The oven stand must be level. Stand legs are adjustable. In addition, the overall height of the oven should be positioned so the operating controls and shelves may be conveniently reached from the front.

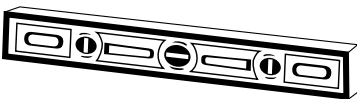

Adjust the height of floor models for smooth access of the trolley or cart. When positioning the oven, observe the minimum space allocation requirements shown.

Level from front-to-back and side-to-side by means of the adjustable legs.

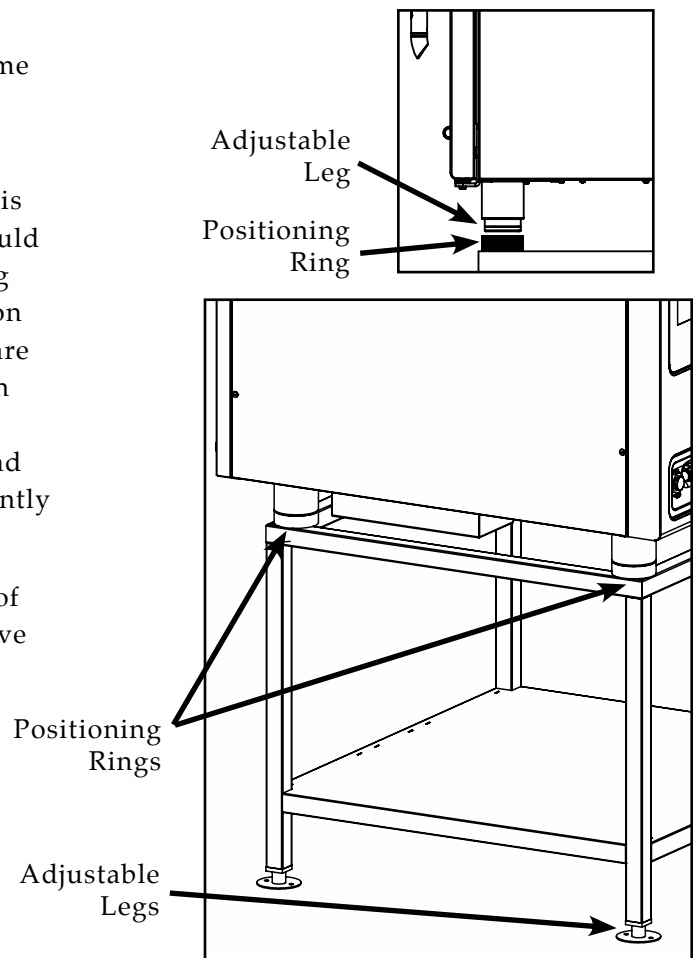

INSTALLATION



SCALE FREE™
CITRUS BASED, NON-CORROSIVE
DELIMING PRODUCT
CE-27889



FRY BASKET
12" x 20"
(325mm x 530mm)
BS-26730



GRILLING GRATE
12" x 20"
(325mm x 530mm)
SH-26731

**POULTRY GREASE
COLLECTION CONTAINER**
15" x 9-3/4" x 9-3/4"
(381 x 248 x 248mm)
5014846

**MOBILE GREASE
COLLECTION CART**
37" x 11-3/16" X 28-1/3"
(940 x 284 x 724mm)
5014542

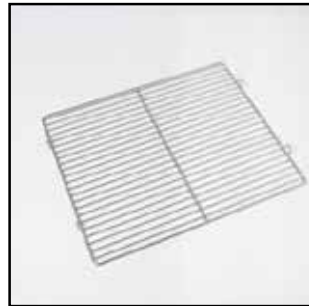

SHELF, STAINLESS STEEL WIRE
*SH-22473 SHOWN



WOOD CHIPS

OPTIONS & ACCESSORIES

<input type="checkbox"/> COMBICLEAN® COMBITABS™ — SPECIALLY FORMULATED FOR COMBITHERM OVENS 90 (1 OUNCE) PACKETS EACH CONTAINER	CE-36354
<input type="checkbox"/> COMBITHERM® CLEANING LIQUID — SPECIALLY FORMULATED FOR COMBITHERM OVENS TWELVE (12) CONTAINERS/CASE, 1 QUART (C. 1 LITER) EACH [SPECIAL HANDLING REQUIRED]	CE-24750
<input type="checkbox"/> LIQUID CLEANER — APPROVED FOR COMBITHERM OVENS EQUIPPED WITH THE OPTIONAL AUTOMATIC LIQUID CLEANING SYSTEM	CE-36457
<input type="checkbox"/> GAS LINE QUICK DISCONNECT	CR-33543
GREASE COLLECTION PAN WITH DRAIN (NOT NEEDED FOR GREASE COLLECTION SYSTEM)	
<input type="checkbox"/> 6-10, 10-10, 20-10 — 1-1/2" (38mm) DEEP	5003463
<input type="checkbox"/> 7-20, 10-20, 20-20 — 1-1/2" (38mm) DEEP	4758
<input type="checkbox"/> 7-20, 10-20, 20-20 — 2-3/4" (70mm) DEEP	14475
<input type="checkbox"/> PROBE, SOUS VIDE	PR-36576
SHELF, STAINLESS STEEL WIRE	
<input type="checkbox"/> 7-20, 10-20	SH-22584
<input type="checkbox"/> 6-10, 10-10, 20-10	SH-2903
<input type="checkbox"/> 20-20	SH-22473
WOOD CHIPS — BULK PACK 20 LB (9 KG)	
<input type="checkbox"/> APPLE	WC-22543
<input type="checkbox"/> CHERRY	WC-22541
<input type="checkbox"/> HICKORY	WC-2829
<input type="checkbox"/> MAPLE	WC-22545

INSTALLATION

ELECTRICAL FOR GAS MODELS

1. An electrical wiring diagram is located behind the control panel on the left side of the oven.

This appliance must be branch circuit protected with proper ampacities, in accordance with the wiring diagram.

2. **DO NOT CONNECT TO A G.F.I. OUTLET.** Random and/or nuisance breaker trips could occur. Consult with the NEC codes for specific load values.

3. Wire size for the main incoming power to the unit must match the minimum size listed in the specifications applicable to the specific oven model. For supply connections, locate the wire size posted on the label located on the electrical control box cover, behind the service panel.

4. Before operating the oven, check all cable connections in the electrical connection area for tightness since connections can loosen during transport.

NOTE: Check motor rotation on the Combitherm® CT Classic CTC model line. Arrows on the motor housing indicate proper rotation.

After both water and electrical connections have been completed on all Combitherm model types, operate the oven in any cooking mode for a period of 15 minutes and recheck the main power connections at the terminal block to make certain they remain tight.

DANGER



ENSURE POWER SOURCE MATCHES VOLTAGE IDENTIFIED ON APPLIANCE RATING TAG.

DANGER



DISCONNECT UNIT FROM POWER SOURCE BEFORE CLEANING OR SERVICING.

DANGER



ELECTRICAL GROUNDING INSTRUCTIONS:

This appliance is equipped with a three-pronged (grounding) plug for your protection against shock hazard and should be plugged directly into a properly grounded three-prong receptacle. Do not cut or remove the grounding prong from this plug.

DANGER



AVERTISSEMENT: Directives pour la prise de courant électrique Cet appareil est muni d'une fiche à trios branches (prise de Courant) afin de vous protéger des chocs et doit être branché Directemet dans un receptacle adequate de prise do courant À trios branches. Il ne faut pas couper ou enlever une banche De cette fiche.

DANGER



To avoid electrical shock, this appliance **MUST** be adequately grounded in accordance with local electrical codes or, in the absence of local codes, with the current edition of the National Electrical Code ANSI/NFPA No. 70. In Canada, all electrical connections are to be made in accordance with CSA C22.1, Canadian Electrical Code Part 1 or local codes.

380-415V:

For CE approved units: To prevent an electrical shock hazard between the appliance and other appliances or metal parts in close vicinity, an equalization-bonding stud is provided. An equalization bonding lead must be connected to this stud and the other appliances / metal parts to provide sufficient protection against potential difference. The terminal is marked with the following symbol.



INSTALLATION

ELECTRICAL FOR ELECTRIC MODELS



DANGER



ENSURE POWER SOURCE
MATCHES VOLTAGE IDENTIFIED
ON APPLIANCE RATING TAG.

DANGER



APPLIANCES WITH NO CORD
PROVIDED BY FACTORY MUST
BE EQUIPPED WITH A CORD OF
SUFFICIENT LENGTH TO PERMIT
THE APPLIANCE TO BE MOVED
FOR CLEANING.



ELECTRICAL CONNECTIONS MUST
BE MADE BY A QUALIFIED SERVICE
TECHNICIAN IN ACCORDANCE WITH
APPLICABLE ELECTRICAL CODES.

Hard wired models:

Hard wired models must be equipped with a country certified external allpole disconnection switch with sufficient contact separation.

If a power cord is used for the connection of the product an oil resistant cord like H05RN or H07RN or equivalent must be used.

1. An electrical wiring diagram is located behind the control panel on the left side of the oven. This appliance must be branch circuit protected with proper ampacities, in accordance with the wiring diagram.
2. **DO NOT CONNECT TO A G.F.I. OUTLET.** Random and/or nuisance breaker trips could occur. Consult with the NEC codes for specific load values.
3. Wire size for the main incoming power to the unit must match the minimum size listed in the specifications applicable to the specific oven model. For supply connections, locate the wire size posted on the label located on the electrical control box cover, behind the service panel.
4. Before operating the oven, check all cable connections in the electrical connection area for tightness since connections can loosen during transport.

DANGER



To avoid electrical shock, this appliance **MUST** be adequately grounded in accordance with local electrical codes or, in the absence of local codes, with the current edition of the National Electrical Code ANSI/NFPA No. 70. In Canada, all electrical connections are to be made in accordance with CSA C22.1, Canadian Electrical Code Part 1 or local codes.



DANGER



IMPROPER INSTALLATION,
ALTERATION, ADJUSTMENT,
SERVICE, OR MAINTENANCE COULD
RESULT IN SEVERE INJURY, DEATH,
OR CAUSE PROPERTY DAMAGE.

READ THE INSTALLATION,
OPERATING AND MAINTENANCE
INSTRUCTIONS THOROUGHLY
BEFORE INSTALLING OR SERVICING
THIS EQUIPMENT.

NOTE: Check motor rotation on the Combitherm® CT Classic CTC model line. Arrows on the motor housing indicate proper rotation.

After both water and electrical connections have been completed on all Combitherm model types, operate the oven in any cooking mode for a period of 15 minutes and recheck the main power connections at the terminal block to make certain they remain tight.

380V/415V Grounded units: To prevent an electrical shock hazard between the appliance and other appliances or metal parts in close vicinity, an equalization-bonding stud is provided. An equalization bonding lead must be connected to this stud and the other appliances / metal parts to provide sufficient protection against potential difference. The terminal is marked with the following symbol.



INSTALLATION

ELECTRICAL CONNECTION



DANGER



ELECTRICAL CONNECTIONS MUST BE MADE BY A QUALIFIED SERVICE TECHNICIAN IN ACCORDANCE WITH APPLICABLE ELECTRICAL CODES.

DANGER



To avoid electrical shock, this appliance **MUST** be adequately grounded in accordance with local electrical codes or, in the absence of local codes, with the current edition of the National Electrical Code ANSI/NFPA No. 70. In Canada, all electrical connections are to be made in accordance with CSA C22.1, Canadian Electrical Code Part 1 or local codes.

3 PHASE WITH NEUTRAL

1 PHASE WITHOUT NEUTRAL

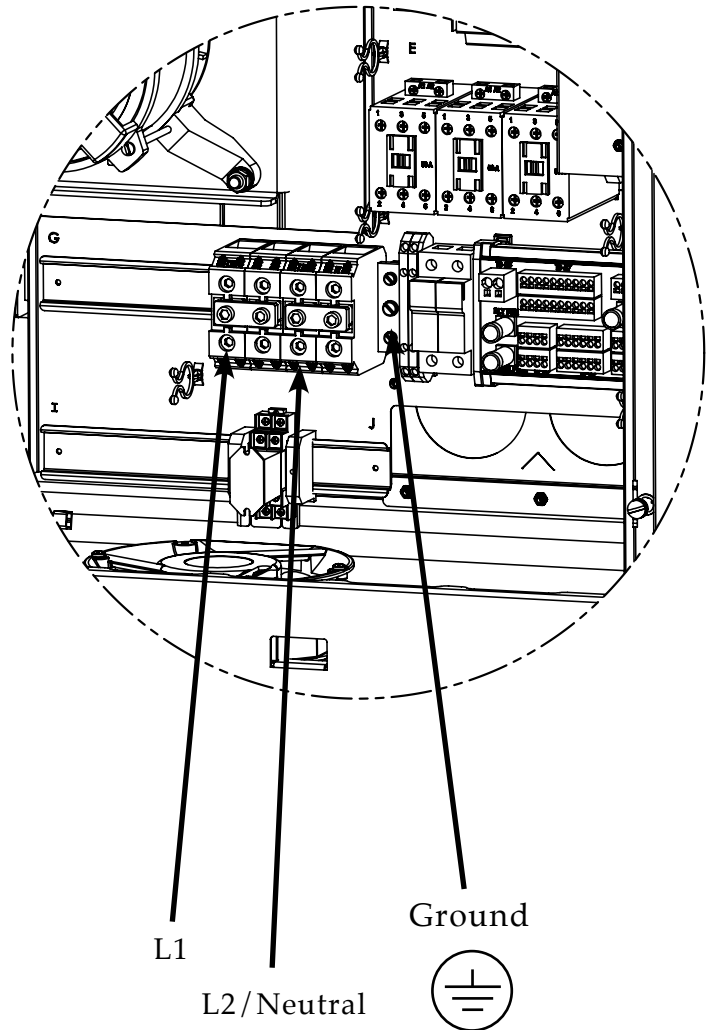
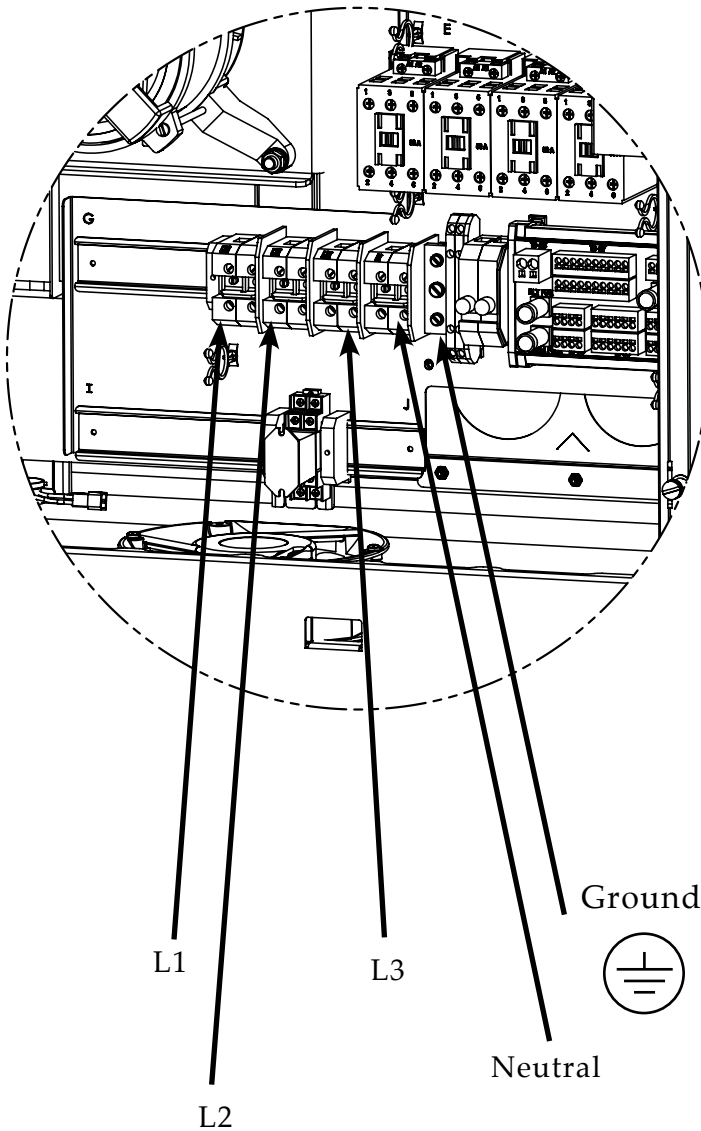

INSTALLATION

MOBILE EQUIPMENT RESTRAINT FOR GAS MODELS

The gas Combitherm must use a connector that complies with *The Standard for Connectors for Movable Gas Appliances*, ANSI Z21.69 CSA 6.16 and addenda Z21.69a-1989. A quick disconnect device must be installed to comply with *The Standard for Quick Disconnect Devices for Use with Gas Fuel*, ANSI Z21 CSA 6.9. and European Standard EN203.

Adequate means must be provided to limit the movement of this appliance. Limitation of movement must be made without depending on the connector, the quick disconnect device, nor the associated piping designed to limit appliance movement. If it becomes necessary to disconnect the restraint, it must be reconnected immediately following the return of the appliance to its original position.

1. Install a manual gas shut-off valve along with an approved disconnect device.
2. Install an A.G.A. certified, heavy-duty connector that complies with ANSI Z 21.69 or CAN 1-6.10m88 along with a quick-disconnect device in compliance with ANSI Z21.41 or CAN 1-6.9m70. Connectors must be installed with a cable restraint to prevent excessive tension from being placed on the connector.



MOBILE EQUIPMENT RESTRAINT FOR ELECTRIC MODELS

Any appliance that is not furnished with a power supply cord but includes a set of casters must be installed with a tether. Adequate means must be provided to limit the movement of this appliance without depending on or transmitting stress to the electrical conduit. The following requirements apply:

1. Casters must be a maximum height of 6" (152mm).
2. Two of the casters must be the locking type.
3. Such mobile appliances or appliances on mobile stands must be installed with the use of a flexible connector secured to the building structure.

A mounting connector for a restraining device is located on the lower back flange of the appliance chassis or on an oven stand, approximately 18" (457mm) from the floor. A flexible connector is not supplied by nor is it available from the factory.

CAUTION

THIS SECTION IS PROVIDED FOR THE ASSISTANCE OF QUALIFIED SERVICE TECHNICIANS ONLY AND IS NOT INTENDED FOR USE BY UNTRAINED OR UNAUTHORIZED SERVICE PERSONNEL.

INSTALLATION

VENTILATION REQUIREMENTS FOR GAS MODELS

DANGER



Installation, air adjustment and/or service work must be in accordance with all local codes and must be performed by a certified service technician qualified to work on gas appliances.

An adequate ventilation system is required for commercial cooking equipment. Information may be obtained by writing to the National Fire Protection Association, Batterymarch Park, Quincy, MA 02269. When writing refer to NFPA No. 96.

1. A single gas Combitherm oven requires a minimum of 28 CFM make-up air for natural and propane gas. Kitchen ventilation must include a provision for an adequate flow of fresh air for gas combustion and to prevent a negative-pressure condition. The bottom of the oven provides air supply access for gas combustion and must be kept clear at all times. **DO NOT** obstruct or restrict ventilation nor the air flow required to support combustion.
2. **DO NOT** obstruct the flow of the exhaust flue at the top rear of the oven. It is especially critical that gas supply piping and electrical support cord and/or receptacle be routed away from the path of the hot combustion fumes.

4. This oven cannot be direct vented.
5. Install the oven under a ventilation hood meeting all applicable code requirements. Combustion fumes must be vented in accordance with local, state, or national codes.

CAUTION



To prevent malfunction or cause negative back draft, DO NOT obstruct exhaust flues or attach any flue extension that will impede proper burner operation.

DANGER



FAILURE TO VENT THIS APPLIANCE PROPERLY MAY BE HAZARDOUS TO THE HEALTH OF THE OPERATOR. Equipment damage, operational problems and unsatisfactory baking performance may also be the consequence of improper venting. Any damage sustained by a failure to properly vent this oven are not covered under warranty.

3. Make certain the oven installation maintains adequate air ventilation to provide cooling for electrical and gas components. The area around the oven should be clear of any obstructions which might retard the flow of cooling air. Failure to observe this caution may result in damage to the components and will void the warranty.

Ventilation hoods and exhaust systems shall be permitted to be used to vent appliances installed in commercial applications.

WARNING



Inadequate ventilation, or failure to ensure an adequate supply of fresh air will result in a high ambient temperature at the rear of the appliance. An excessive ambient temperature can cause the thermal-overload protection device on the blower motor to trip resulting in severe damage to the blower motor.

Where automatically operated appliances are vented through a ventilation hood or exhaust system equipped with a damper or with a power means of exhaust, provisions shall be made to allow the flow of gas to the main burners only when the damper is open to a position to properly vent the appliance and when the power means of exhaust is in operation. IN ACCORDANCE WITH NFPA 54 COMMONWEALTH OF MASSACHUSETTS ONLY.

INSTALLATION

GAS SUPPLY & INSTALLATION

The Alto-Shaam gas Combitherm has been set to operate with either natural gas or propane as indicated on the identification name plate. Make certain the gas supply matches the nameplate information. Should conversion to the opposite fuel be desired, conversion parts must be ordered from the factory. Conversion must be completed by a qualified service person only. **Always remember to reflect the conversion on the oven's nameplate.** Residential gas connections and hard-piped gas connections *DO NOT* meet NSF certifications.

Please refer to model specifications for rated thermal loads and connected pressure requirements.

WARNING	
	<p>TO AVOID SERIOUS PERSONAL INJURY, installation of this appliance must conform to local, state, and national codes; the current edition of the American National Standard Z223.1, National Fuel Gas Code, and all local municipal building codes. In Canada, installation must be in accordance with Standard CAN/CSA B 149.1 and Installation Codes - Gas Burning Appliances, and local codes.</p>

DANGER	
	<p>CONNECTING TO THE WRONG GAS SUPPLY COULD RESULT IN FIRE OR AN EXPLOSION CAUSING SEVERE INJURY AND PROPERTY DAMAGE.</p>

Natural	Cat	Gas Type
DK/EE/FI/GR/HU/IS/IT/NO	II2H3B/P	2H-G20-20mbar
RO/SE/SK/CY/PL/TR	II2H3B/P	2H-G20-20mbar
ES/FR/GB/IE/PT/SI/CZ	II2H3P	2H-G20-20mbar
AT/CH	II2H3B/P	2H-G20-20mbar
BE	II2E(S)B3P	2H-G20-20mbar
DE	II2ELL3B/P	2E-G20-20mbar
Propane	Cat	Gas Type
DK/EE/FI/GR/HU/IS/IT/NO	II2H3B/P	3B/P-G30/G31-30mbar
RO/SE/SK/CY/PL/TR	II2H3B/P	3B/P-G30/G31-30mbar
ES/FR/GB/IE/PT/SI/CZ	II2H3P	3P-G31-30mbar
AT/CH	II2H3B/P	3B/P-G30/G31-50mbar
BE	II2E(S)B3P	3P-G31-30mbar
DE	II2ELL3B/P	3B/P-G30/G31-50mbar
NL	II2L3B/P	3B/P-G30/G31-50mbar
NL	II2L3B/P	2L-G25-25mbar
AUS/NZ		NGN 1,0kPa
AUS/NZ		LPG-X Propane 2.75 kPa
Japan		Natural Gas 13A 1.96 kPa
Japan		LPG - Propane 2.8 kPa

INSTALLATION

GAS SUPPLY & INSTALLATION

WARNING



TO AVOID SERIOUS PERSONAL INJURY, installation of this appliance must conform to local, state, and national codes; the current edition of the American National Standard Z223.1, National Fuel Gas Code, and all local municipal building codes. In Canada, installation must be in accordance with Standard CAN/CSA B 149.1 and Installation Codes - Gas Burning Appliances, and local codes.



DANGER



CONNECTING TO THE WRONG GAS SUPPLY COULD RESULT IN FIRE OR AN EXPLOSION CAUSING SEVERE INJURY AND PROPERTY DAMAGE.

INSTALLATION REQUIREMENTS

GAS CONNECTION: 3/4" NPT

For Europe, gas connection thread fittings should conform to EN ISO 228-1, or ISO 7-1, or shall have a compression fitting.

MINIMUM OUTLET MANIFOLD PRESSURE REQUIRED:
CHECK PLUMBING CODES FOR PROPER SUPPLY LINE SIZING TO ATTAIN PRESSURES LISTED BELOW.

NOTE: If a flexible gas line is used, it must be AGA approved, commercial type and at least 3/4" I.D. or comply to European Standard EN203.

HOOD INSTALLATION IS REQUIRED

After installation, burner and gas valve should be checked and adjusted by a qualified Alto-Shaam technician. GAS VALVE MAY REQUIRE FIELD ADJUSTMENT ABOVE 2,000' (610m) AND IS NOT ADJUSTED AT THE FACTORY.



DANGER



DISCONNECT UNIT FROM POWER SOURCE BEFORE CLEANING OR SERVICING.

SPRING VALVE ADJUSTMENT

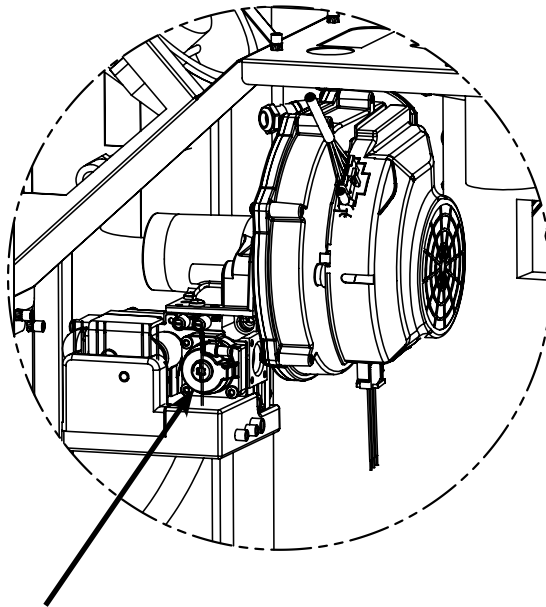

To adjust the burner pressure, rotate clockwise to increase the pressure or counter-clockwise to decrease the pressure.

INSTALLATION

GAS SUPPLY & INSTALLATION

DANGER



Installation, air adjustment and/or service work must be in accordance with all local codes and must be performed by a certified service technician qualified to work on gas appliances.

Remove any tape or compound residue on all external thread connections before proceeding. Use an approved gas pipe sealant at all external threaded connections,

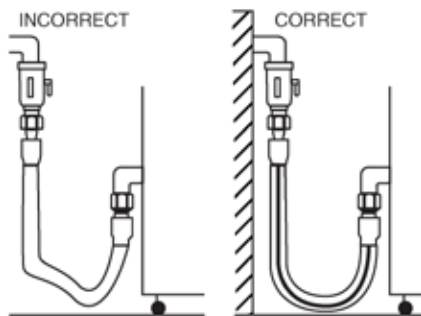

Gas piping used on gas connections must avoid sharp bends that may restrict the flow of gas to the appliance. If the connected pressure exceeds 14.0" W.C. (3.5 kPa), a step-down regulator is required to be supplied by the owner/operator.

Close the individual manual shut-off valve to ***isolate the appliance*** from the gas supply piping system during any pressure testing at test pressures equal to or less than 1/2 psig. (3,4 kPa). The appliance and individual shut-off valve ***must be disconnected*** from the gas supply piping system during any pressure testing at pressures in excess of 1/2 psig. (3,4 kPa).

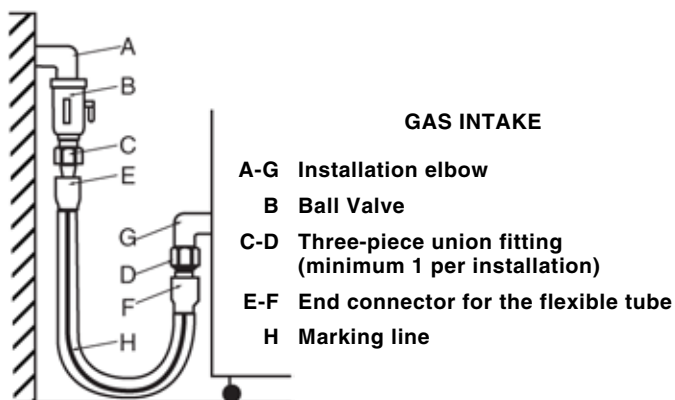

DANGER



DO NOT store or use gasoline or other flammable vapors or liquids in the vicinity of this or any other appliance.

DANGER



NE PAS entreposer ni utiliser d'essence ou d'autres vapeurs ou liquides inflammables à proximité de cet appareil ou de tout autre appareil.

DANGER



DO NOT spray aerosols in the vicinity of this appliance while it is in operation.

In the U.S.A., installation must conform to local codes or, in the absence of local codes, with the current edition of the *National Fuel Gas Code*, NFPA-54 and ANSI Z83.11a CSA 1.8a 2004 (or latest edition). In Canada, installation must be in accordance with local codes, CAN/CGA-B149.1, *Installation for Natural Gas Burning Appliances and Equipment* (latest edition) or CAN/CGAB149.2 *Installation for Propane Burning Appliances and Equipment* (latest edition). In Europe, installation must be in accordance with European Standard EN203.

The inlet supply line must be properly sized to accommodate all individual appliances simultaneously used on the same line but must never be smaller than 3/4" NPT.

CAUTION



MAKE CERTAIN THE AREA AROUND THE APPLIANCE IS KEPT CLEAR OF COMBUSTIBLE ITEMS.

INSTALLATION

GAS SUPPLY & INSTALLATION

The minimum size requirement for gas piping or a flexible connector is 3/4 - inch (19mm). For long runs of gas piping, the pipe diameter must conform to the tables in the National Fuel Gas Code, ANSI/NFPA Z223.1 or European Standard EN203.

A listed gas shut-off valve must be installed upstream of the appliance to shut off the gas supply during servicing. The shut-off valve should be accessible with the appliance in the normal installation position.

If the oven or the oven stand is supplied with casters, gas connection must be made with a flexible connector that complies with the Standard for Connectors for Movable Gas Appliances, ANSI Z21.69; or in Canada, Connectors for Movable Gas Appliances, CAN/CGA-6.16-M87. When using a flexible connector, a quick disconnect device must be used to comply with the Standard for Quick-Disconnect Devices for Gas Fuels, ANSI Z21.41; or in Canada, Quick Disconnect Devices for Use with Gas Fuels, CAN1-6.9 or European Standard EN203.

When a quick disconnect device and flexible connector are used, a restraining device must be installed to limit the movement of the appliance and prevent damage to the connector or quick disconnect. An example of a restraining device would consist of a 2000 pound test, stainless steel cable, attached to a structural member of the kitchen wall behind the oven. The means of attachment should consist of a quick connect snap so that the oven can be disconnected when the appliance must be moved away from the wall.

The other end of the cable should be permanently attached to the rear frame of the oven. The cable should be of sufficient length so that no strain is ever placed on the flexible gas connector in the event of accidental movement of the oven without properly disconnecting the gas connector. The flexible connector should be routed to form a downward "U" loop between the building gas supply and the permanent attachment at the rear of the oven.

The routing of the flexible connector must not be made under the oven. Oven temperatures achieved during operation are too hot for safe operation. Gas piping should be installed from the point of gas connection at the bottom, front of the oven to the back of the oven where the flexible connector may be safely used. See the illustration for the recommended placement.



INSTALLATION

GAS SUPPLY & INSTALLATION

LEAK TESTING

If a pressure leak test above 1/2 psi (34,5 mbar) is to be performed on the building supply gas piping, the shut-off gas valve and oven inlet gas supply line must be disconnected from the building supply piping before conducting the pressure test. Failure to do so may result in damage to the manual gas valve, gas components in the oven, or both.

If any gas leak tests are to be conducted at pressures equal to or below 1/2 psi (34,5 mbar), the manual gas shut-off valve upstream of the oven must be turned off before conducting the tests.

Leak testing of the internal oven piping system was conducted before shipping the oven from the factory. If additional testing is needed, it should only be conducted at normal gas supply pressures. If the testing is performed using combustible gas in the piping, the leak checking should be done with a soap solution (bubble checking).

The use of an electronic combustible gas leak detector is helpful, however, this type of detector can be oversensitive. Electronic detectors may indicate false leaks from other sources which would not be detected when checking with a liquid solution to verify a no-hazard gas connection.

When starting the oven after initial installation, the gas lines must be free of air. It may take up to 30 minutes to eliminate all air from the lines. If, after this time there is no pilot, call for factory assistance.

 DANGER	
	NEVER USE AN OPEN FLAME TO LEAK TEST.

GAS EXHAUST

The oven is not designed for direct connection to a chimney vent system or for direct connection to a horizontal exhaust system.

The oven must be installed under a ventilation hood listed to ANSI/UL 705 (latest edition), and the installation must be completed in accordance with the ANSI/NFPA 96-1987, Standard for Ventilation Control and Fire Protection of Commercial Cooking Operations.

Oven operators should be instructed with regard to the hazards of placing any material on top of the oven that would obstruct the flow of flue products out the opening of the flue diverter. Operators should also be instructed with regard to the hazards of hot flue gases and that any material or items placed on top of, or in front of the flue deflector could be damaged or cause a fire hazard.

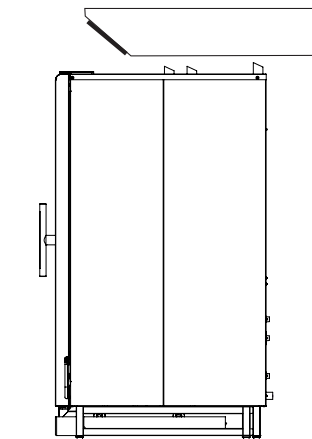

DANGER	
	BEFORE STARTING THE APPLIANCE, MAKE CERTAIN YOU DO NOT DETECT THE ODOR OF GAS. IF THE ODOR OF GAS IS DETECTED: <ul style="list-style-type: none">• DO NOT attempt to light any appliance.• DO NOT touch any electrical switches.• Extinguish any open flame.• Use a telephone OUTSIDE THE PROPERTY & IMMEDIATELY contact your gas supplier.• If unable to contact your gas supplier, contact the fire department.

INSTALLATION

WATER SUPPLY & INSTALLATION

WATER QUALITY REQUIREMENTS

USE A DRINKING QUALITY, COLD WATER SUPPLY ONLY

Water quality is of critical importance when installing steam producing equipment of any kind, particularly *high temperature* steam producing equipment. Water that is perfectly safe to drink is composed of chemical characteristics that directly affect the metal surfaces of steam producing equipment. These chemical characteristics differ greatly from region to region throughout the U.S. and the world. *Varying combinations of pH; alkalinity; hardness; chlorides; total dissolved solids; and other chemical characteristics, when subjected to high temperatures, will cause water to have a tendency to either scale or corrode.*

Alto-Shaam has consulted with people who understand the properties of water in order to provide water quality standards that meet the broadest possible range of acceptable water quality requirements to help protect your investment.

We strongly urge water testing to ascertain the water quality on site prior to the installation of any steam producing equipment. Since water quality is an important issue, Alto-Shaam is committed to provide as much information as possible to help protect the investment made in this equipment.

A water filtration system, when properly installed, maintained, and combined with the required levels of steam generating equipment maintenance, will help lessen the affect water has on metal surfaces. It will not, however,

provide complete protection against all water damage from region to region.

Due to the complexity of water chemistry, it is important to understand that water quality plays a significant role in the longevity of steam producing equipment. Water quality and required maintenance of steam generating equipment is the direct responsibility of the owner/operator. Damage incurred as a direct result of poor water quality and/or surfaces affected by water quality is also the responsibility of the owner/operator. Damage due to water quality that does not meet the minimum standards shown below is not covered under the Alto-Shaam Combitherm warranty.

It is the sole responsibility of the owner/operator/purchaser of this equipment to verify that the incoming water supply is comprehensively tested and if required, a means of "water treatment" provided that would meet compliance requirements with the published water quality standards published at right. Non-compliance with these minimum standards will potentially damage this equipment and/or components and VOID the original equipment manufacturer's warranty. Alto-Shaam recommends using OptiPure® [www.optipurewater.com] products to properly treat your water.

Alto-Shaam will continue our efforts to provide viable solutions to ease the impact of water quality as it relates to steam generating equipment.

ALTO-SHAAM COMBITHERM WATER QUALITY MINIMUM STANDARDS

CONTAMINANT	INLET WATER REQUIREMENTS (UNTREATED WATER)
Free Chlorine	Less than 0.1 ppm (mg/L)
Hardness	30-70 ppm
Chloride	Less than 30 ppm (mg/L)
pH	7.0 to 8.5
Silica	Less than 12 ppm (mg/L)
Total Dissolved Solids (tds)	50-125 ppm

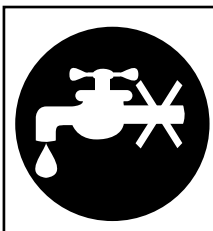

WARNING

TO PREVENT WATER PIPES FROM BURSTING, INCOMING WATER SUPPLY SHOULD BE TURNED OFF WHEN THE APPLIANCE IS NOT IN USE.



WARNING

WATER SUPPLY MUST BE OPEN WHEN CLEANING PROGRAM IS ACTIVATED. VERIFY WATER SUPPLY BEFORE STARTING CLEANING PROGRAM.

INSTALLATION

WATER SUPPLY & INSTALLATION

- Flush the water line at the installation site.
- Install water intake filters (provided) [see Figure 1] before connecting the oven to the water supply.
- **Backflow Prevention** — The equipment must be installed with adequate backflow protection to comply with applicable federal, state, and local codes.
- **PIPE SEALING TAPE (TEFLON®) MUST BE USED AT ALL CONNECTION POINTS.** The use of a pipe sealing compound is not recommended.

WATER REQUIREMENTS

TWO (2) COLD WATER INLETS - DRINKING QUALITY

ONE (1) TREATED WATER INLET:	3/4" NPT*	* Can manifold off of one
ONE (1) UNTREATED WATER INLET:	3/4" NPT*	3/4" line.
LINE PRESSURE:	30 to 90 psi	2.1 to 6.3 bar
WATER DRAIN: 1-1/2" (40mm) CONNECTION WITH A 2" MINIMUM AIR GAP INSTALLED AS CLOSE TO THE OVEN AS POSSIBLE. MATERIALS MUST WITHSTAND TEMPERATURES UP TO 200°F (93°C).		

NOTE:

BOTH TREATED AND UNTREATED WATER CONNECTIONS MUST BE CONNECTED FOR PROPER OPERATION OF THE OVEN. BOTH CONNECTIONS CAN BE TREATED WATER, BUT SHOULD NEVER BE CONNECTED TO ONLY UNTREATED WATER.

UNIONS OR FLEXIBLE LINES SHOULD BE USED TO ALLOW FOR OVEN MOVEMENT WHEN BEING SERVICED OR CLEANING IS NEEDED.

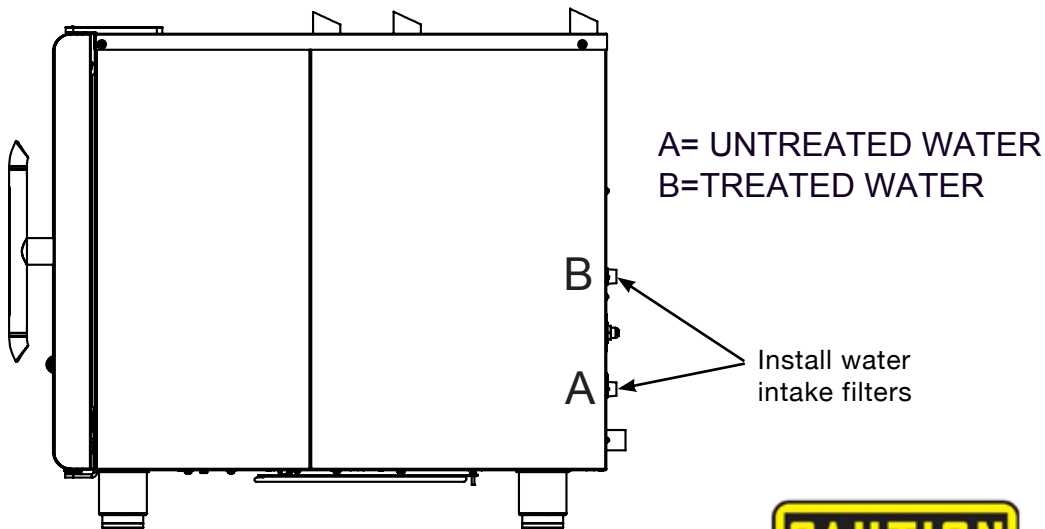

Figure 1



INSTALLATION

WATER DRAINAGE - EACH OVEN

A union is required. Install a 1-1/2-inch (41mm) diameter connection, drain line and clamp into place. The drain line must always be a positive gradient away from the Combitherm oven and not more than 12-inches (305mm) before an air gap. A 1/2-inch (13mm) air gap is required.

NOTE: In the U.S.A., this equipment is to be installed to comply with the Basic Plumbing Code of the Building Officials and Code Administrators International, Inc. [BOCA], and the Food Service Sanitation Manual of the Food & Drug Administration [FDA].

Note: Failure to connect the drain correctly can result in poor performance and/or damage the oven.

Drain materials must withstand temperatures up to 200°F (93°C)

Example installation

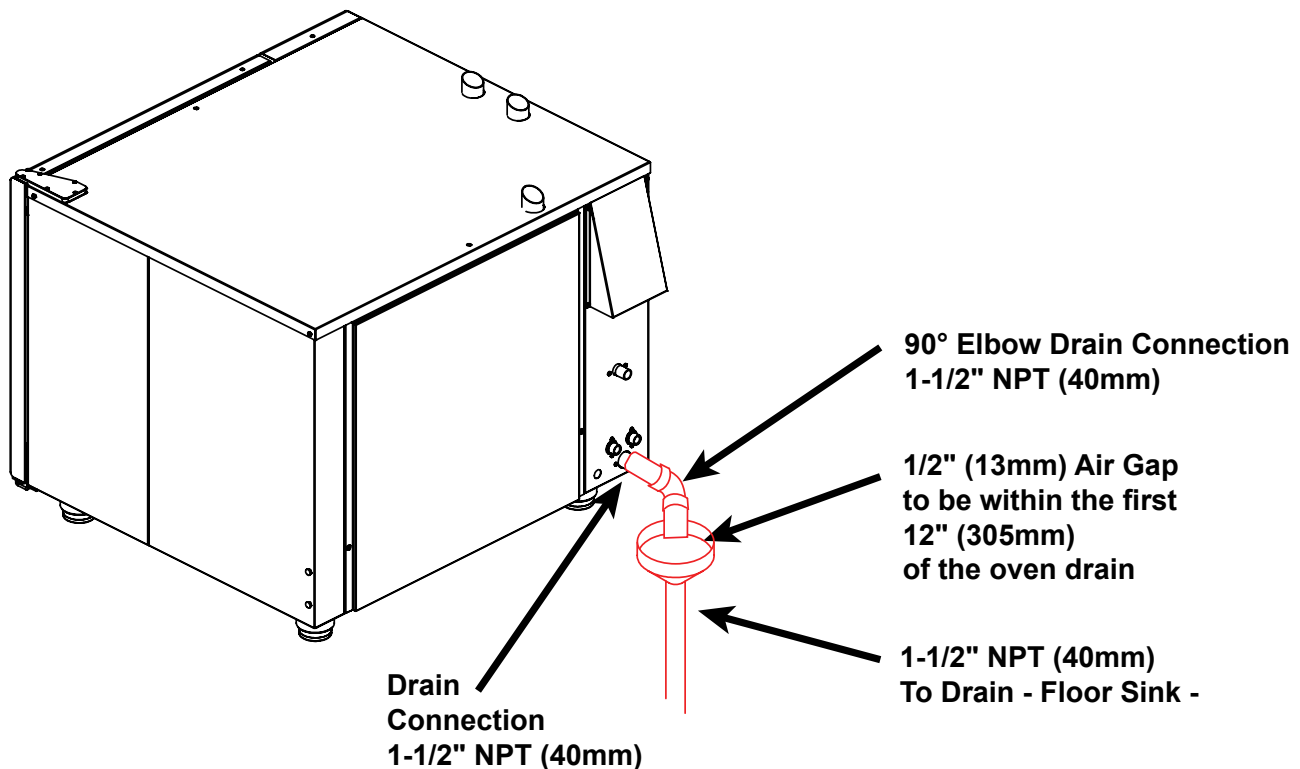

INSTALLATION

WATER DRAINAGE - EACH OVEN

A union is required. Install a 1-1/2-inch (41mm) diameter connection, drain line and clamp into place. The drain line must always be a positive gradient away from the Combitherm oven and not more than 12-inches (305mm) before an air gap. A 1/2-inch (13mm) air gap is required.

NOTE: In the U.S.A., this equipment is to be installed to comply with the Basic Plumbing Code of the Building Officials and Code Administrators International, Inc. [BOCA], and the Food Service Sanitation Manual of the Food & Drug Administration [FDA].

Note: Failure to connect the drain correctly can result in poor performance and/or damage the oven.

Example installation

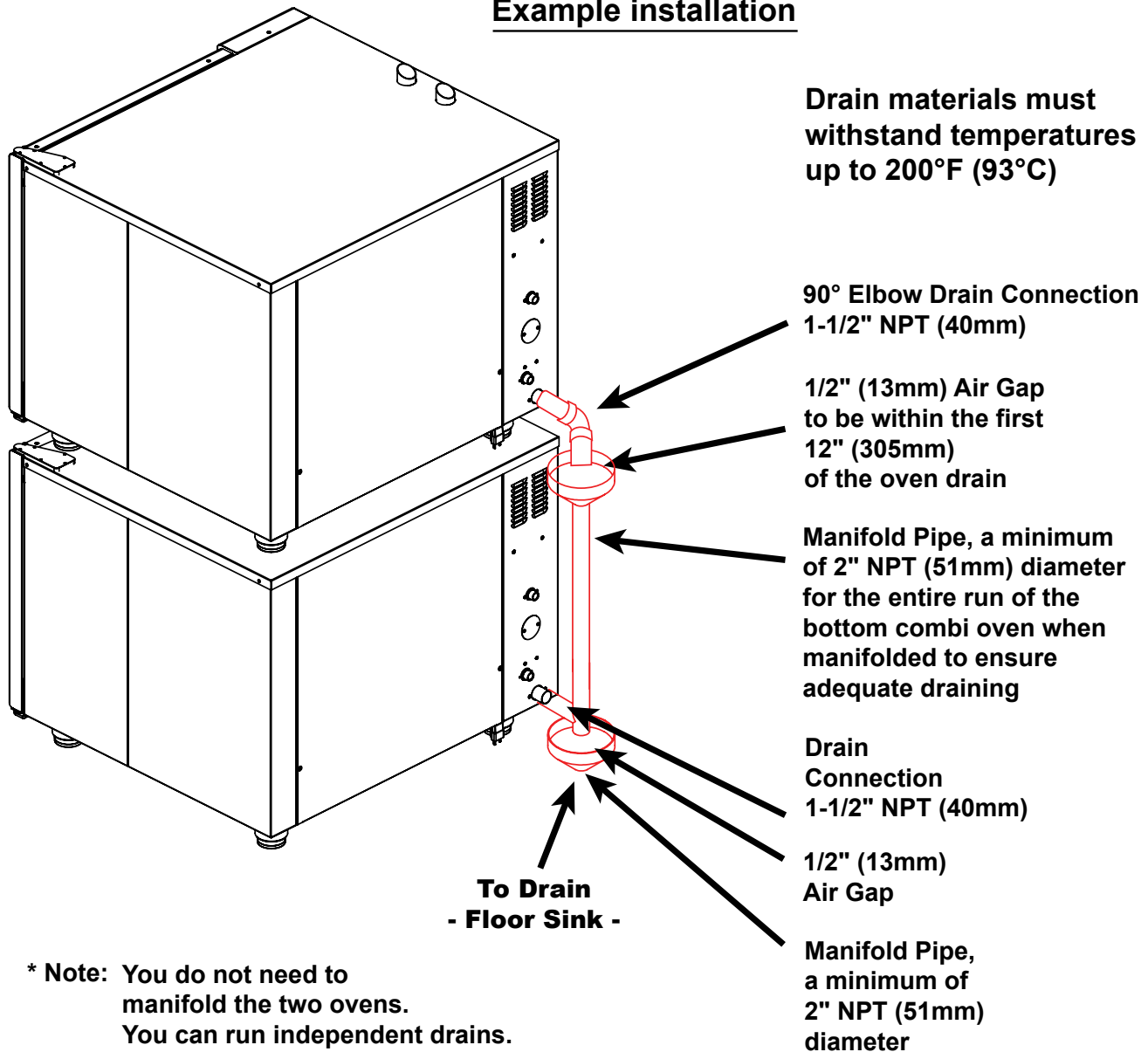

INSTALLATION

COMBIHOOD PLUS™ VENTLESS HOOD OPTION

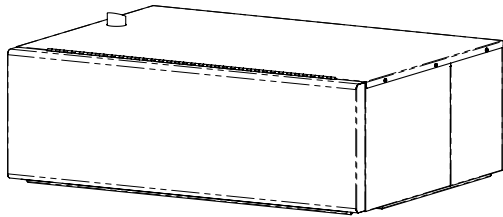

The CombiHood PLUS option is factory installed directly on the top of the Alto-Shaam Combitherm CTP or CTC series oven.

- Using EPA method 202 testing, grease laden vapors emitted by the Combi Ventless hood are 0.58 mg/m^3 – far less than U.L.’s established standard of 5 mg/m^3 .
- Alto-Shaam’s factory installed Ventless Hood is placed directly on the top of a Combitherm oven.
- A high-power fan captures all steam and fumes from the oven cavity into the hood intake and out the back surface exhaust vent, trapping grease as the air moves through the filter system.
- As fumes and vapors are circulated through the hood, condensed steam drains from a drain at the rear of the hood.
- An activated charcoal filter cleans the air before venting it out the top of the hood.
- CombihoodPLUS™ performance is “smart”; engaging the fan during the last minute of the cook mode which provides quiet operation and consumes less power.

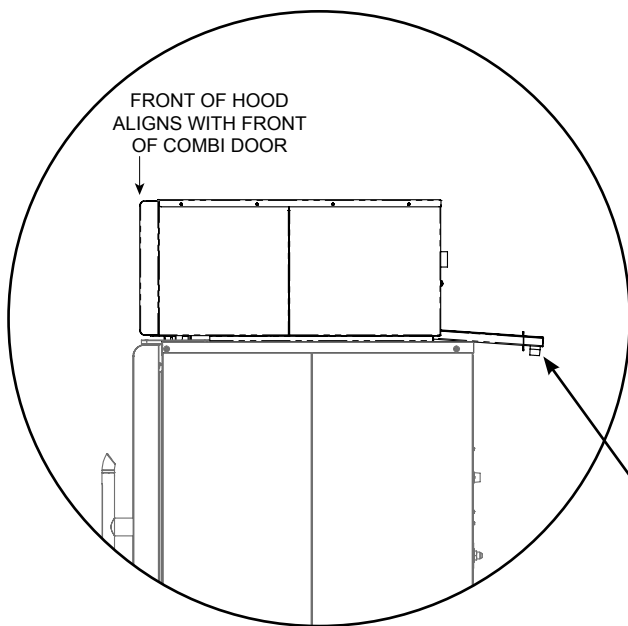

CONDENSATE DRAIN

A ventless hood condensate drain line to the floor drain must be installed. The 3/4" NPT thread connection is found at the back of the hood. The drain line must always be a positive gradient away from the Combitherm oven.

INSTALLATION

COMBIHOOD PLUS™ VENTLESS HOOD OPTION

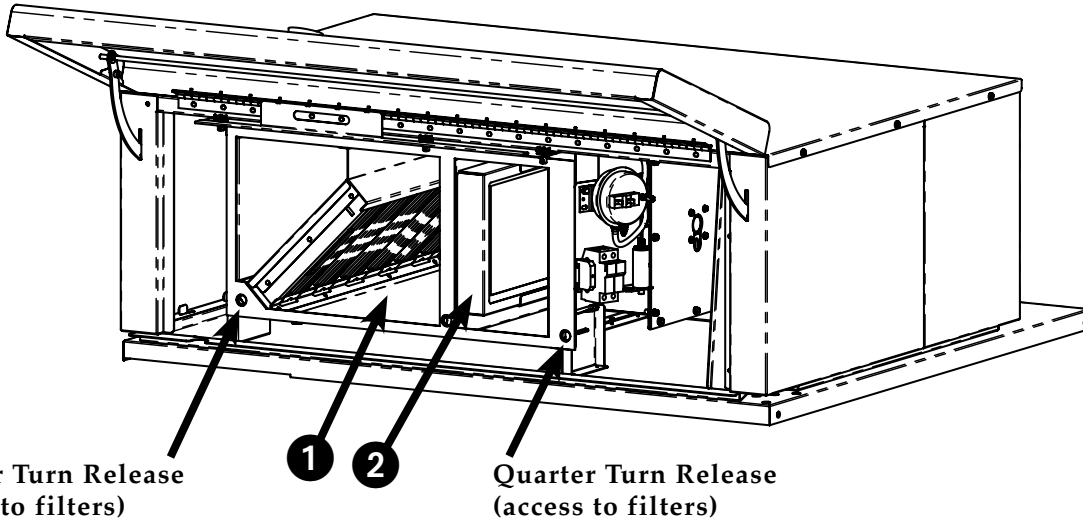

Quarter Turn Release
(access to filters)

Quarter Turn Release
(access to filters)

1 Grease Filter (FI-25867):

Cleaning frequency should be based on oven usage with a maximum of two weeks between cleaning if the oven is used for non-grease laden products or steam applications only. Grease laden products require cleaning frequency of at least once a week.

Remove the grease filter by pulling it straight out of the housing. Place the filter in the dishwasher or wash separately by placing in hot, soapy water until all grease and particles have been removed. Rinse thoroughly. Allow the filter to air dry before reinstalling.

To replace the grease filter, the air flow arrow on the filter casing should be pointing toward the hood fan.

2 Charcoal Filter (Class I - FI-36620):

The charcoal filter should be inspected for contaminant's on a regular basis. Replacement must be made at a minimum of three month intervals — more often if heavy contaminant's are visible or if the filter no longer controls odors.

To remove the filter, pull and slide out while holding the bottom housing. When replacing the filter, make certain the air flow arrow(s) point toward the hood fan, and that the filter is replaced in the three-sided metal frame provided with the hood.

NOTE:

A pressure switch is used to detect when the airflow through the charcoal filter is reduced by 25% - indicating a possible blockage. This will generate an E101 error message on the oven control display. The filters will need to be cleaned or replaced.

If the filters are not seated properly, an error code E102 will appear on the oven control display at the end of a cooking cycle.

INSTALLATION

GREASE COLLECTION HOOK-UP (IF EQUIPPED WITH THIS FEATURE)

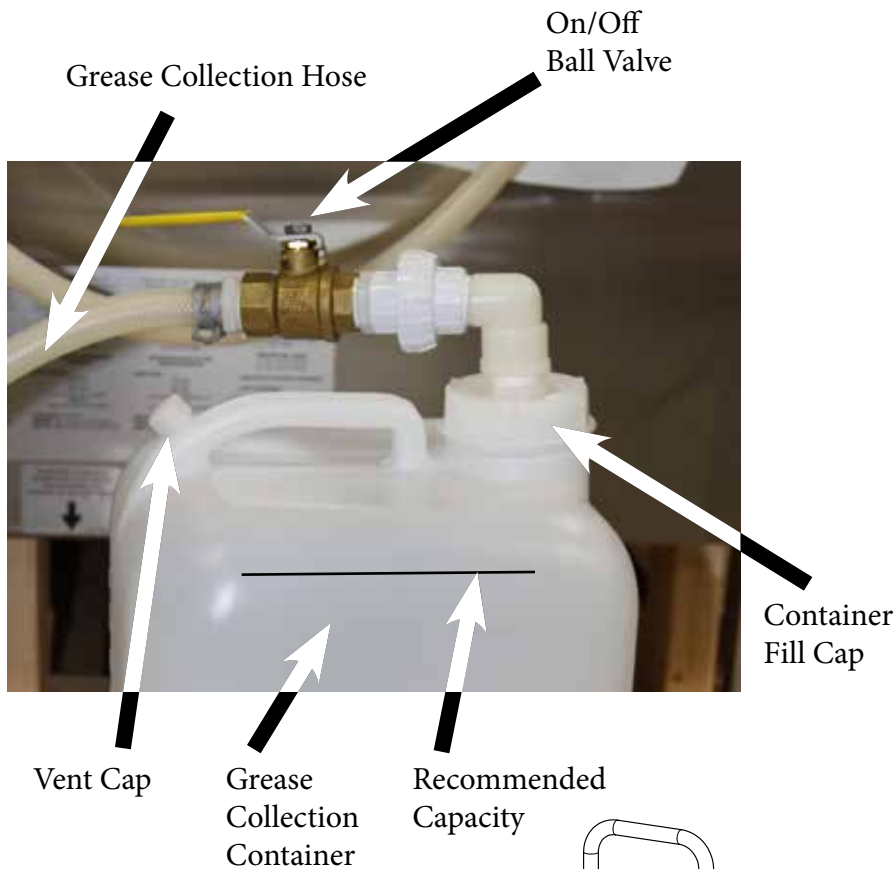

- Grease Collection Hose Assembly is attached to the oven in the back.
- Place Grease Collection Containers inside the tray of the Mobile Grease Collection Cart. Roll into place next to the oven.
- **Loosen vent cap on container.** Pull out the Grease Collection Hose Assembly from the back of the unit. Remove collection container fill cap.
- Screw Grease Collection Hose Assembly on to collection container until snug.
- Turn ball valve handle to the **ON** position.
- If this auxiliary function has been chosen while setting your cooking mode, the automatic grease collection system is electronically activated during the cooking process [PATENT PENDING]. It is designed to save labor and provide greater employee safety by eliminating the need to handle hot grease in shallow pans.

- Grease Collection container has a 5 gallon capacity and holds approximately 3 full loads of poultry grease.
- It is suggested to change the container when material reaches the fill line on the bottle or at 4 gallons to avoid hot grease overflow.
- Turn the ball valve handle to the **OFF** position.
- The ball valve handle must be in the **OFF** position when changing the collection container.
- Unscrew the container fill cap.
- Using a new container, screw Grease Collection Hose Assembly on to collection container until snug.
- Turn ball valve handle to the **ON** position.

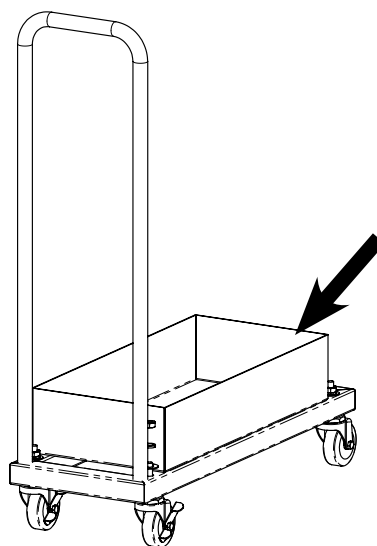

Optional
Mobile
Grease
Collection
Cart

INSTALLATION

LIQUID CLEANER HOOK-UP (IF EQUIPPED WITH THIS OPTION)

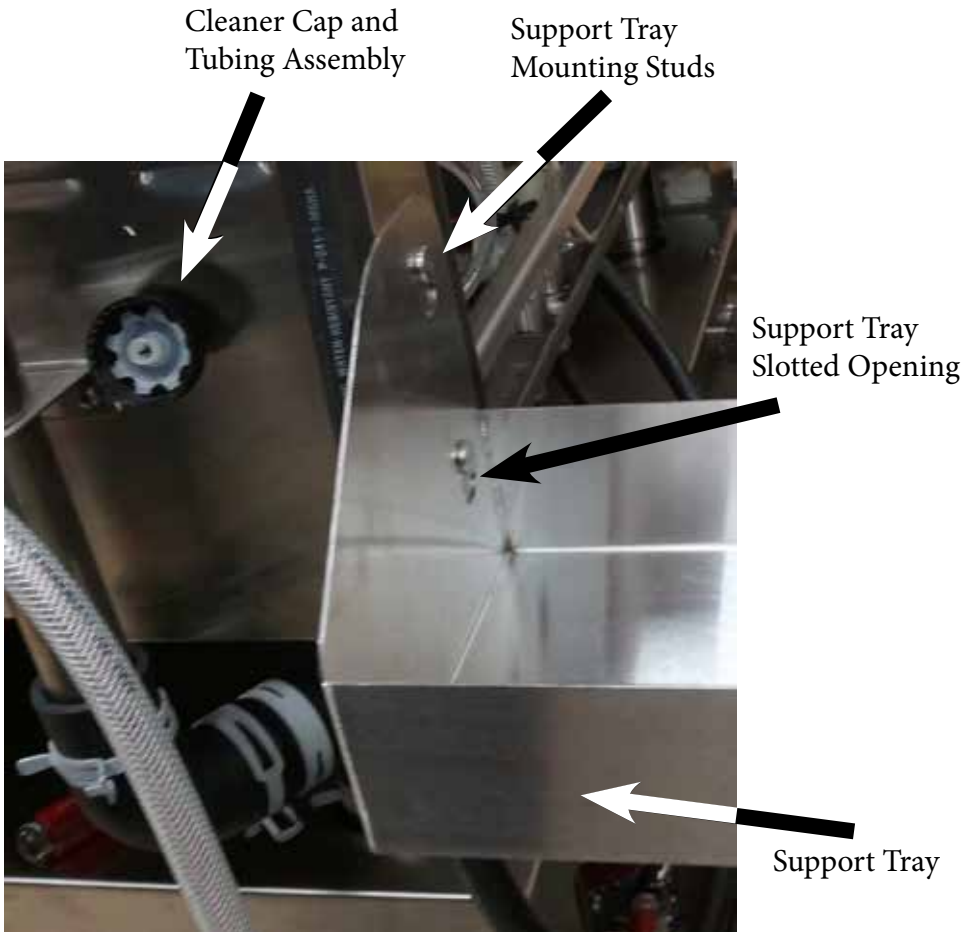

- Removable, cleaner support tray can be mounted on the left or right exterior wall of the oven. Slide slotted openings on the tray over the mounting studs.
- Support tray holds a 2-1/2-gallon bottle and measures 10-1/2" x 7-3/4" (267mm x 194mm).
- Place liquid oven cleaner bottle inside tray.
- **Wearing protective rubber gloves and eye wear**, remove cap from liquid oven cleaner bottle. Pull out the Cleaner Cap and Tubing Assembly from the back of the unit screw on to liquid oven cleaner bottle.
- Combitherm liquid oven cleaner jugs are quickly and easily replaced.
- Combitherm liquid oven cleaner is automatically pumped through the system, saving labor and providing greater employee safety by eliminating the need to handle caustic cleaning liquids each day.



DANGER

PROTECTIVE EYE WEAR MUST BE WORN WHEN USING LIQUID OVEN CLEANER.



DANGER

RUBBER GLOVES MUST BE WORN WHEN USING LIQUID OVEN CLEANER.

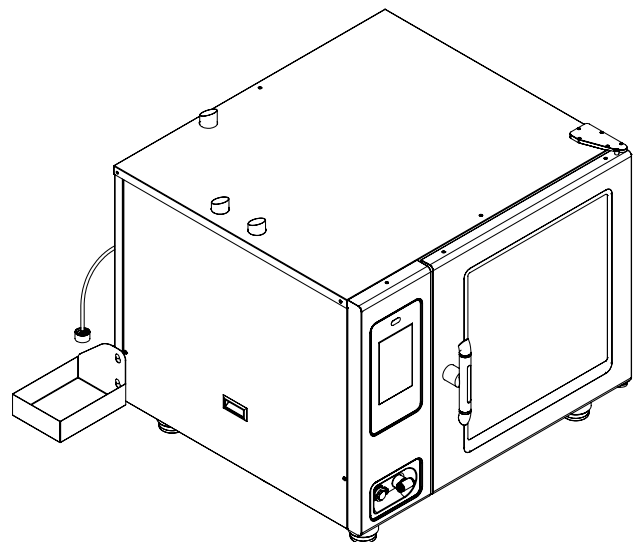

OPERATION

CT PROFORMANCE™ START-UP PROCEDURES



Power ON - Activates power to the oven and automatically fills the steam generator equipped models with water that will heat to a stand-by mode temperature of 188°F (77°C).



Power OFF - Press once to initiate power shut down sequence to the oven. **Note:** Oven will not shut down during a cooking cycle. You may need to press firmly due to the material thickness. From time to time, the control may become unresponsive. **ONLY** in this case, firmly press and hold the OFF key for 10 seconds to power down the oven.



When the oven is powered on, the PROtouch screen illuminates. “Loading” indicates that the software is booting up. The screen will also indicate what level of progress has been made as the software becomes fully operational. See illustration at left.

If, for any reason, the oven is turned off or loses power during this start-up process, the operator will be prompted to calibrate the Touch screen when the oven is next powered up.



Return to Home Screen - Press the red arrow if the PROtouch™ screen *does not* need to be calibrated.



Begin Calibration Process - Press the green check mark if the Touch screen *does* need to be calibrated. The screen will switch to a grey background. See illustration at right. A crosshairs icon will appear. The operator should touch the center intersection using a stylus for an accurate calibration. This prompt and required action will be repeated several times in different areas of the Touch screen. When complete, the operator will be returned to the Home screen.



NOTE: In the event of a power failure, the oven will not operate.





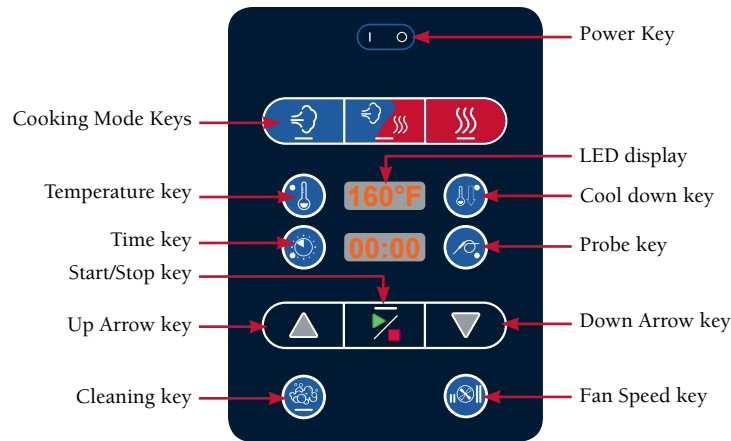





OPERATION

CT CLASSIC™ START-UP PROCEDURES



Turn on and preheat the oven

Alto-Shaam recommends preheating the Combitherm® before cooking.

- Press the **Power** key. 
- Choose a **Mode**.  Steam  Combi  Convection
- Press **Oven Temperature** key; adjust temperature with arrow keys.   
- Press **Cook Time** Key; adjust time with arrow keys.   
- Press the **Start/Stop** key. 
- Preheat oven before loading food.

NOTE: In the event of a power failure, the oven will not operate.

COMBITHERM® POST INSTALLATION CHECKLIST

Post installation check sheet power off. Verify all mains before switching CombiOven on for the first time. Note any non-compliant requirements and correct before turning the CombiOven on.

CUSTOMER INFORMATION:

Date of Installation:

Street Address:

Customer Name:

City:

State:

Zip:

CLEARANCES:

Write the actual measured distances in the boxes provided:

Left:

0" (0mm) required - 18" (457mm) recommended for service access

Back:

4" (102mm) required

Right:

0" (0mm) from non-combustible surfaces;
2" (51mm) from combustible surfaces

Top:

20" (508mm) required

Are all clearance requirements met?

YES NO

WATER SUPPLY AND DRAINS:

Verify hook up of two (2) separate **COLD** water lines with a 3/4" (19mm) Water connection supply line. Verify Inlet water pressure is at a minimum of 30 PSI (2.1 bar). Maximum water pressure is not to exceed 90 PSI (6.3 bar). **IMPORTANT:** *Alto-Shaam has listed water quality requirements in the installation manual for this equipment. It is the responsibility of the end user to have the water being connected to this appliance tested to ensure it meets with these standards. Failure to meet with these standards can void the warranty of the equipment if water quality is found to be the reason of the failure.*

Has a filtration system been installed?

YES NO

Type?

Has a complete water Analysis been complete?

YES NO

Static water pressure:

ELECTRICAL CONNECTIONS:

Rated Voltage:

Rated Phase:

Breaker Size:

Actual Voltage:

L1-N

L2-N

L3-N

L1-L2

L1-L3

L2-L3

Gas Connections

Rated Gas Supply

Nat

LP

Actual Gas Supplied

Nat

LP

NOTE: *Improper drain connections can result in equipment failure. Alto-Shaam drain requirements are located in the installation manual for this equipment. Failure to meet these standards can void warranty if the failure is found to have been caused by an improperly connected drain. It is the responsibility of the installer to ensure the manufactures requirements are met in the plumbing of the drain system.*

DRAIN:

Type of material used for drain?

Is a 2" (51mm) air gap installed?

YES

NO

Is the air gap within 12" (305mm) of the CombiOven?

YES

NO

Is the drain piped with a positive descending slope?

YES

NO

Use the diagrams provided to create a simple diagram showing how the drain plumbing is ran. Include measurements showing the distance to the floor drain, location of the air gap, and venting of the drain. Drain plumbing requirements can be found in the installation manual.

NOTES:

COMBITHERM® POST INSTALLATION CHECKLIST CONTINUED

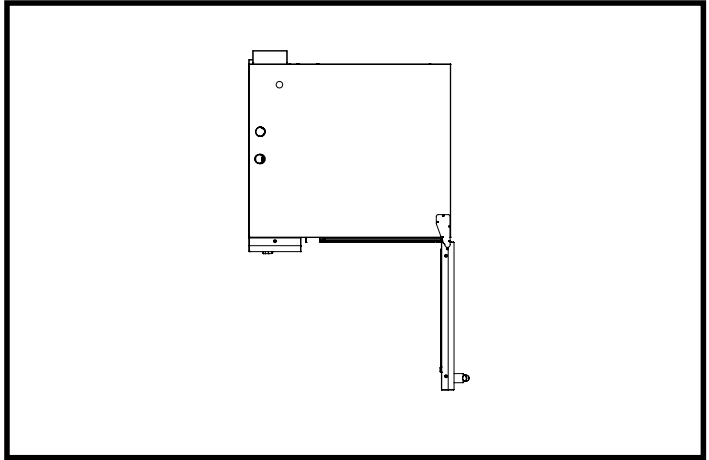
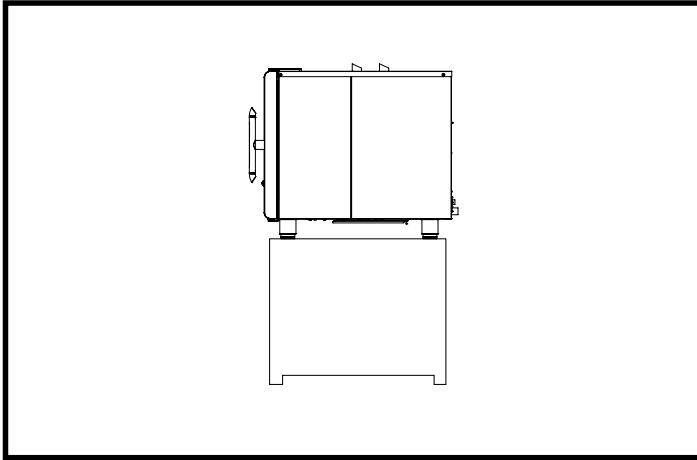

Post installation check sheet Power on. Check that all mains are within the correct tolerances before switching CombiOven on for the first time.

POWER ON:

Current factory software versions: IB OB CB Record software version installed: IB OB CB

FUNCTION TEST:

Cycle Y1	Operation fill/Steam injection	<input type="checkbox"/> YES	<input type="checkbox"/> NO
Cycle Y2	Operation condensate cooling valve	<input type="checkbox"/> YES	<input type="checkbox"/> NO
Cycle Y3	Operation rinse solenoid valve	<input type="checkbox"/> YES	<input type="checkbox"/> NO
Dynamic water pressure with Y1	<input type="text"/>	Dynamic water pressure with Y3	<input type="text"/>
Dynamic water pressure with Y2	<input type="text"/>		
Start oven in steam mode and record Amperage	L1 <input type="text"/>	L2 <input type="text"/>	L3 <input type="text"/>
Start oven in convection and record Amperage	L1 <input type="text"/>	L2 <input type="text"/>	L3 <input type="text"/>

GAS OVENS:

With the burner on, check the following: Dynamic pressure to the valve

Flue gas analysis: Co2% Co pmm

INSTALLATION COMPLETE:

Clean up job site	<input type="checkbox"/> YES	<input type="checkbox"/> NO
Wipe down and clean exterior of CombiOven	<input type="checkbox"/> YES	<input type="checkbox"/> NO
Picture of screen displaying current software versions	<input type="checkbox"/> YES	<input type="checkbox"/> NO
Picture of drain with air gap	<input type="checkbox"/> YES	<input type="checkbox"/> NO
Picture of water connections at CombiOven connections	<input type="checkbox"/> YES	<input type="checkbox"/> NO
Picture of gas line and connections at CombiOven	<input type="checkbox"/> YES	<input type="checkbox"/> NO
Picture of unit in place with surrounding equipment	<input type="checkbox"/> YES	<input type="checkbox"/> NO

COMPANY INFORMATION:

Company Name: <input type="text"/>	Installing Technician: <input type="text"/>
Street Address: <input type="text"/>	City: <input type="text"/> Zip: <input type="text"/>
Technician Signature: _____	Print Name: _____
Customer Signature: _____	Print Name: _____

TROUBLE SHOOTING

ERROR CODES

This section is provided for the assistance of qualified technicians only and is not intended for use by untrained or unauthorized service personnel. If your Alto-Shaam® unit is not operating properly, check the following before calling your Authorized Alto-Shaam Service Agent:

- ☛ Check that unit is receiving power. Circuit breaker turned on?

Do not attempt to repair or service the oven beyond this point. Contact Alto-Shaam for the nearest authorized service agent. Repairs made by any other service agents without prior authorization by Alto-Shaam will void the warranty on the unit.

When the oven malfunctions, an error code will appear in the display.

 **PRESS THE START ICON TO ACKNOWLEDGE THE ERROR.**

When the oven error notification has been acknowledged, the Combitherm will attempt to return to normal operation.

Error Code	Error Call Out in Display	Description of Error	Possible Cause
E01	Low Water Boiler	Upper water level probe B1 is not satisfied within 5 minutes, after water solenoid valve Y1 is activated.	<ul style="list-style-type: none"> — Water supply is shut off. — Low water pressure. — Boiler drain cap is missing. — Boiler drain pump is defective. — Drain pump elbow leaking. — Water level probe has calcium build up. — Double water solenoid valve is defective (Y1). — Relay board, high voltage is defective.
E02	Control Temperature High	Low voltage relay board temperature higher than 176°F (80°C).	<ul style="list-style-type: none"> — Check wiring to all components listed below. — Cooling fan on relay board assembly is defective. — Cooling fan on display board assembly is defective. — Main cooling fan is defective. — Cooling fan on motor drive is defective.
E03	Fan Motor Error	Fan motor does not spin after 60 seconds, detected by the Hall Sensor. Error 03 does not appear if error E53 is detected first.	<ul style="list-style-type: none"> — Check wiring to all components listed below. — If LED on motor control flashes, see error codes for motor control. — Motor or fan wheel locked. — Hall sensor does not detect motor rotation. — Motor Thermo Temperature protection. — Fan wheel damaged.
E04	Lower Fan Motor Error	Lower Fan motor does not spin after 60 seconds, detected by the Hall Sensor. Error 04 does not appear if error E54 is detected first.	<ul style="list-style-type: none"> — Check wiring to all components mentioned below. — If LED on motor control flashes, see error codes for motor control. — Motor or fan wheel locked. — Hall sensor does not detect motor rotation. — Motor Thermo Temperature protection. — Fan wheel damaged.
E05	VFD Comm Failure	When VFD does not respond to a query on the CAN interface.	<ul style="list-style-type: none"> — Loss of power to VFD. — VFD malfunction. — CAN cable disconnected. — CAN address not correct on VFD.
E06	Lower VFD Comm Failure	When VFD does not respond to a query on the CAN interface.	<ul style="list-style-type: none"> — Loss of power to VFD. — VFD malfunction. — CAN cable disconnected. — CAN address not correct on VFD.

CONTINUED ON NEXT PAGE

TROUBLE SHOOTING

ERROR CODES

Error Code	Error Call Out in Display	Description of Error	Possible Cause
E07	Error Received from VFD	When VFD is flashing the green light	— Refer to VFD error code list and match to number of blinks on the green LED of VFD.
E08	Error Received from Lower VFD	When VFD is flashing the green light	— Refer to VFD error code list and match to number of blinks on the green LED of VFD.
E11	Convection Temperature High	In Combination program, cavity temperature N6 is measuring in excess of 572°F (300°C) for a minimum of 25 seconds In Convection program, cavity temperature N6 is measuring in excess of 572°F (300°C) for a minimum of 25 seconds	— Check wiring to all components mentioned below. — Steam element contactor locked/on. — N6 oven cavity temperature probe is defective. — N6 oven cavity temperature probe wires connected backwards — Relay board, high voltage, defective.
E13	Boiler Temperature High	Boiler temperature is more than 248°F (120°C) for more than 25 seconds, detected by B4 Probe	— Calcium build up in boiler — Check wiring to all components mentioned below. — Steam element contactor locked/on. — B4 boiler temperature probe is defective. — B4 probe wires connected backwards — Water level probe has calcium build up.
E15	Condensor Temperature High	Condensor water temperature is more than 212°F (100°C) for more than 180 seconds, detected by B3 probe	— Water supply is shut off. — Check wiring to all components mentioned below. — B3 condensor temperature probe is defective. — B3 condensor probe wires connected backwards — Single water solenoid valve defective (Y2). — Relay board, high voltage, defective.
E20	B11 Core Temperature Probe Single Point Fault	Single point core temperature probe defective or disconnected	— Clean probe receptacle pins with sand paper. — B11 Single Point Core Temperature probe with quick connect defective. — B11 Single Point Core Temperature probe wires with quick connect disconnected. — B11 Single Point Core Temperature probe receptacle defective. — B11 Single Point Core Temperature probe receptacle wires disconnected.
E21	N6 Cavity Probe Fault	Cavity temperature probe defective or disconnected	— N6 oven cavity temperature probe defective. — N6 oven cavity temperature probe wires.
E22	B10 Core Temperature Probe Multi-point Fault	Multipoint core temperature probe defective or disconnected	— B10 multipoint core temperature probe defective. — B10 multipoint core temperature probe wires disconnected.

CONTINUED ON NEXT PAGE

TROUBLE SHOOTING

ERROR CODES

Error Code	Error Call Out in Display	Description of Error	Possible Cause
E23	B4 Boiler Probe Fault	Boiler temperature probe defective or disconnected	<ul style="list-style-type: none"> — B4 boiler temperature probe defective. — B4 probe wires connected backwards.
E24	B5 Bypass Probe Fault	Bypass steam temperature probe defective or disconnected	<ul style="list-style-type: none"> — B5 bypass steam temperature probe defective. — B5 bypass steam temperature probe wires connected backwards.
E25	B3 Condensor Probe Fault	Condensor water temperature probe defective or disconnected.	<ul style="list-style-type: none"> — B3 condensor temperature probe defective. — B3 condensor probe wires connected backwards.
E26	N8 Boiler Safety Temperature Probe Fault	Boiler heating element protection probe defective or disconnected.	<ul style="list-style-type: none"> — N8 boiler temperature probe defective. — N8 probe wires connected backwards.
E27	Boiler Element Temperature High	Boiler protection heat element temperature is more than 266°F (130°C) for more than 25 seconds, detected by N8 probe.	<ul style="list-style-type: none"> — Calcium build up in boiler. — Check wiring to all components mentioned below. — Steam element contactor locked/on. — N8 boiler temperature probe defective. — N8 probe wires connected backwards. — Water level probe has calcium buildup.
E34	Steam Generator Drain Pump Fault	If water level does not drop below lower water level probe after three minutes when steam generator drain pump is activated in cleaning program.	<ul style="list-style-type: none"> — Calcium build up in steam generator drain pump. — Boiler drain pump defective. — Relay board, high voltage, defective. — Water level probe defective.
E36	Steam Temperature High	<p>In Steam program, cavity temperature N6 is measuring in excess of 395°F (200°C) for more than 60 Seconds.</p> <p>In Combination program, cavity temperature N6 is measuring in excess of 520°F (270°C), for more than 60 Seconds.</p> <p>In Retherm program, cavity temperature N6 is measuring in excess of 395°F (200°C), for more than 60 Seconds.</p> <p>In Cleaning program, cavity temperature N6 is measuring in excess of 395°F (200°C), for more than 60 Seconds.</p>	<ul style="list-style-type: none"> — Water supply is shut off. — Low water pressure. — Water injection pipe, calcium build up. — Water flow valve defect or calcium build up. — Double water solenoid valve defective (Y1). — Relay board, high voltage, defective.
E40	B3 Fault	B3 probe shorted to ground	<ul style="list-style-type: none"> — Defective or miswired probe.
E41	B4 Fault	B4 probe shorted to ground	<ul style="list-style-type: none"> — Defective or miswired probe.
E42	B5 Fault	B5 probe shorted to ground	<ul style="list-style-type: none"> — Defective or miswired probe.
E43	N6 Fault	N6 probe shorted to ground	<ul style="list-style-type: none"> — Defective or miswired probe.
E44	N8 Fault	N8 probe shorted to ground	<ul style="list-style-type: none"> — Defective or miswired probe.
E45	B10 Fault	B10 probe shorted to ground	<ul style="list-style-type: none"> — Defective or miswired probe.

CONTINUED ON NEXT PAGE

TROUBLE SHOOTING

ERROR CODES

Error Code	Error Call Out in Display	Description of Error	Possible Cause
E51	No Water In Boiler	Lower water level probe B2 is not satisfied within 5 minutes, after water solenoid valve Y1 is activated	<ul style="list-style-type: none"> — Water supply is shut off. — Low water pressure. — Boiler drain cap missing. — Boiler drain pump defective. — Drain pump elbow leaking. — Water level probe has calcium build up. — Double water solenoid valve defective (Y1). — Relay board, high voltage, defective.
E53	Fan Motor High Temperatures	Fan motor does not spin, result in over-heating, detected by motor coil safety thermo element. Temperature more than 320°F (160°C).	<ul style="list-style-type: none"> — Motor high limit open or wired incorrectly. — If LED on motor control flashes, see error codes for motor control. — Motor or fan wheel locked. — Fan wheel damaged.
E54	Lower Fan Motor High Temperature	Lower fan motor does not spin, result in over-heating, detected by motor coil safety thermo element. Temperature more than 320°F (160°C).	<ul style="list-style-type: none"> — Motor high limit open or wired incorrectly. — If LED on motor control flashes, see error codes for motor control. — Motor or fan wheel locked. — Fan wheel damaged.
E55	Vent Not Open	60 seconds after the venting motor is activated the vent motor safety switch did not open.	<ul style="list-style-type: none"> — Alignment issue between motor cam and vent motor safety switch (micro switch). — Faulty vent valve (motor). — Faulty vent valve safety switch (micro switch).
E56	Vent 2 not open	60 seconds after the venting motor is activated the vent motor safety switch did not open.	<ul style="list-style-type: none"> — Alignment issue between motor cam and vent motor safety switch (micro switch). — Faulty vent valve (motor). — Faulty vent valve safety switch (micro switch).
E57	No Rinse Water	Flow switch for solenoid valve Y4 does not detect any water flow for a minimum of 60 seconds.	<ul style="list-style-type: none"> — Water supply is shut off. — Low water pressure. — Flow switch is dirty or defective. — Double water solenoid valve defective (Y3). — Relay board, high voltage, defective.
E88	Lower Gas Ignition Failure	Reset output from Ignition Module is ON	<ul style="list-style-type: none"> — Hot surface ignitor not functioning. — No gas supply. — Flame sensor not functioning. — Faulty ignition control.
E89	Upper Gas Ignition Failure	Reset output from Ignition Module is ON	<ul style="list-style-type: none"> — Hot surface ignitor not functioning. — No gas supply. — Flame sensor not functioning. — Faulty ignition control.
E90	Lower Gas Combustion Blower Not at Speed	Speed is too slow.	<ul style="list-style-type: none"> — Power supply cable is not connected to blower motor. — Speed control cable is not connected to blower motor. — Blower motor is blocked, rotation is impeded, or motor is faulty. — Faulty control board.

CONTINUED ON NEXT PAGE

TROUBLE SHOOTING

ERROR CODES

Error Code	Error Call Out in Display	Description of Error	Possible Cause
E91	Upper Gas Blower Not at Speed	Speed is too slow.	<ul style="list-style-type: none"> — Power supply cable is not connected to blower motor — Speed control cable is not connected to blower motor — Blower motor is blocked, rotation is impeded, or motor is faulty — Faulty control board
E92	Communication Error CB does not properly respond	Twelve (12) instances of no-response from the relay board (CB) to the display board (IB).	<ul style="list-style-type: none"> — Check CAN cable connections mentioned below. — CAN cable defective. — Relay board, low voltage, connector defective. — Display board connector defective.
E94	Communication Error, TO Interface Board	No signal transfer for more than 5 seconds between the Interface Board (IB) and the Control Board (CB).	<ul style="list-style-type: none"> — Check CAN cable connections mentioned below. — CAN cable defective. — Relay board, low voltage, connector defective. — Display board connector defective.
E100	One or more maintenance reminder has timed out.	When any maintenance reminder has expired without action having been taken by the operator.	<ul style="list-style-type: none"> — Enter maintenance reminder screen and address the item that has timed out and reset
E101	Ventless Hood Fault - No Pressure	If the power switch or pressure switch is not closed.	<ul style="list-style-type: none"> — Check power switch is on. — Check vent motor is turning in the proper direction. — Pressure switch is mis-wired or defective. — Filter(s) require cleaning or replacement
E102	Ventless Hood Fault — Filters Not Present	If the air filter switches are not closed.	<ul style="list-style-type: none"> — Check filters are installed and properly seated. — Check filter switches are not damaged, defective or dislodged.
E103	Option Board Doesn't Send Switch Setting	OB not communicating its switch settings to the CB.	<ul style="list-style-type: none"> — Check CAN cable connection between OB and CB. — Ensure CB dip switch is set to see an OB. — Incompatible OB and CB software (update software). — OB defective. — CB defective.
E104	Option Board Not Communicating	Option board is not communicating with CB.	<ul style="list-style-type: none"> — Check option board CAN connection at CB and OB. — Defective OB. — Defective CB.
E105	No or Low Water Pressure	Water pressure switch not activated.	<ul style="list-style-type: none"> — Water supply not connected. — Water supply is shut off. — Water supply to unit blocked or obstructed — Faulty or miswired pressure switch
E106	Boiler Drain Pump Fault	Hall effect or rotational sensor is not sending a signal to the relay board	<ul style="list-style-type: none"> — Drain pump motor not running or defective. — Hall effect sensor broken or incorrectly wired. — Motor improperly wired.

CONTINUED ON NEXT PAGE

TROUBLE SHOOTING

ERROR CODES

Error Code	Error Call Out in Display	Description of Error	Possible Cause
E108	Cooling Fan Failure	If the temperature on the control board (relay board) is greater than 140°F (60°C) and less than 176°F (80°C). (See error code E02)	<ul style="list-style-type: none"> — Cooling fan damaged. — Cooling fan blocked or blades have been kept from rotating. — Incoming air temperature exceeds 100°F (38°C). — Air inlet has become blocked.
E109	High Limit Switch	The High Limit Switch input to the CB (N7) is “open”	<ul style="list-style-type: none"> — Unit has experienced an over heat condition. — Convection element contactors stuck closed. — Failed Y1 solenoid. — Obstruction between Y1 solenoid and injection pipe. — Improperly connected drain. — Condensate pan clean out not closed. — Improperly wired high limit switch at the switch or at the CB. — Defective high limit switch.

SEE MOTOR CONTROL ERROR CHART ON NEXT PAGE

INSTALLATION

TOUCH MOTOR CONTROL ERROR CODES

Type of Error	Indication	Release of Error
Undervoltage	LED flashing sequence, with 1 flash per period.	Voltage of intermediate circuit is less than 250V
Overvoltage	LED flashing sequence, with 2 flashes per period.	Voltage of intermediate circuit exceeds 445V
Excess Temperature	LED flashing sequence, with 3 flashes per period.	Temperature sensor in the power unit is more than 199°F (93°C)
Current Peak	LED flashing sequence, with 4 flashes per period.	Blocked motor, detected by current peak monitoring from 900 rpm rotating field
Overcurrent	LED flashing sequence, with 5 flashes per period.	Intermediate circuit current exceeds 4.0 A
Short-circuit	LED flashing sequence, with 6 flashes per period.	Release of interrupt at intermediate circuit current larger than 53 A
Power on	LED flashing sequence, with 7 flashes per period.	Effective mains voltage does not correspond to jumper setting 115V/230V
Watchdog	LED flashing sequence, with 8 flashes per period.	Watchdog of the microcontroller released, program crash

SERVICE PARTS

Item	Part	Description	
1	5014934	Directional Panel, 6-10E	
	5016376	Directional Panel, 6-10G	
	5014936	Directional Panel, 10-10E	
	5016377	Directional Panel, 1010G	
	5014935	Directional Panel, 7-20E	
	5016273	Directional Panel, 7-20G	
	5014937	Directional Panel, 10-20E	
	5016274	Directional Panel, 10-20G	
	5015293	Directional Panel, 20-10E	
	5016378	Directional Panel, 20-10G	
	5015294	Directional Panel, 20-20E	
	5016281	Directional Panel, 20-20G	
	2	GS-35235	Door Gasket, 6-10E, 6-10G
		GS-35236	Door Gasket, 10-10E, 10-10G
		GS-35238	Door Gasket, 7-20E, 7-20G
GS-35239		Door Gasket, 10-20E, 10-20G	
GS-35237		Door Gasket, 20-10E, 20-10G	
GS-35240		Door Gasket, 20-20E, 20-20G	
3	5016194	Drain Screen	
4	FE-35178	Leg, Adjustable, 6-10, 10-10, 7-20, 10-20	
5	1013175	Side Racks, Left or Right, 6-10	
	1013717	Side Racks, Left or Right, 10-10	
	1013189	Side Racks, Left or Right, 7-20	
	1013716	Side Racks, Left or Right, 10-20	
6	1013141	Side Rack Stop, 6-10, 7-20	
	1013724	Side Rack Stop, 10-10, 10-20	
7	5016536	Smoker Tray	

ORIGINAL EQUIPMENT LIMITED WARRANTY

Alto-Shaam, Inc. warrants to the original purchaser that any original part that is found to be defective in material or workmanship will, at Alto-Shaam's option, subject to provisions hereinafter stated, be replaced with a new or rebuilt part.

The labor warranty remains in effect one (1) year from installation or fifteen (15) months from the shipping date, whichever occurs first. Alto-Shaam will bear normal labor charges performed by an authorized Alto-Shaam service agent during standard business hours, excluding overtime, holiday rates or any additional fees.

The parts warranty remains in effect for one (1) year from installation or fifteen (15) months from the shipping date, whichever occurs first. An optional extended warranty is available but must be purchased with the original equipment order. Please consult the factory for net pricing options and details.

THIS WARRANTY DOES NOT APPLY TO:

1. Replacement of wear parts, including light bulbs, door gaskets, and/or the replacement of glass due to damage of any kind.
2. Equipment damage caused by accident, shipping and handling, improper installation or alteration of any kind.
3. Equipment chassis or component/system damage as a result of inadequate routine maintenance and cleaning. Required maintenance and cleaning of steam generating equipment is the responsibility of the owner/operator.
4. Equipment used under conditions of abuse, neglect, misuse, carelessness or abnormal conditions including, but not limited to, equipment subjected to non-approved or inappropriate chemicals including, but not limited to, compounds containing chlorine, chlorides or quaternary salts, or equipment with missing or altered serial numbers. Damage caused by use of any cleaning agent other than Alto-Shaam's Combitherm® Oven Cleaner including, but not limited to, damage due to chlorine, bleach, quaternary salts, souring powders or other harmful chemicals. Use of Alto-Shaam's Combitherm® Cleaner on Combitherm ovens is highly recommended.
5. It is the sole responsibility of the owner/operator/purchaser of this equipment to verify that the incoming water supply is comprehensively tested and if required, a means of "water treatment" provided that would meet compliance requirements with the published water quality standards published at right.
Non-compliance with these minimum standards will potentially damage this equipment and/or components and VOID the original equipment manufacturer's warranty. Alto-Shaam recommends using OptiPure® products to properly treat your water.
6. Any losses or damage resulting from malfunction, including loss of product or consequential or incidental damages of any kind.
7. Equipment damage resulting from modification in any manner from original model, substitution of parts other than factory authorized parts, removal of any parts including legs, or addition of any parts.

COMBITHERM WATER QUALITY MINIMUM STANDARDS

CONTAMINANT	INLET WATER REQUIREMENTS
Free Chlorine	Less than 0.1 ppm (mg/L)
Hardness	30-70 ppm
Chloride	Less than 30 ppm (mg/L)
pH	7.0 to 8.5
Silica	Less than 12 ppm (mg/L)
Total Dissolved Solids (tds)	50-125 ppm

THIS WARRANTY IS EXCLUSIVE AND IS IN LIEU OF ALL OTHER WARRANTIES, EXPRESSED OR IMPLIED, INCLUDING THE IMPLIED WARRANTIES OF MERCHANTABILITY AND FITNESS FOR A PARTICULAR PURPOSE. IN NO EVENT SHALL ALTO-SHAAM BE LIABLE FOR LOSS OF USE, LOSS OF REVENUE OR PROFIT, OR LOSS OF PRODUCT, OR FOR ANY INDIRECT, INCIDENTAL OR CONSEQUENTIAL DAMAGES.

No person except an officer of Alto-Shaam, Inc. is authorized to modify this warranty or to incur on behalf of Alto-Shaam any other obligation or liability in connection with Alto-Shaam equipment.

WARRANTY EFFECTIVE **January 1, 2014**

TRANSPORTATION DAMAGE AND CLAIMS



All Alto-Shaam equipment is sold F.O.B. shipping point, and when accepted by the carrier, such shipments become the property of the consignee.

Should damage occur in shipment, it is a matter between the carrier and the consignee. In such cases, the carrier is assumed to be responsible for the safe delivery of the merchandise, unless negligence can be established on the part of the shipper.

1. Make an immediate inspection while the equipment is still in the truck or immediately after it is moved to the receiving area. Do not wait until after the material is moved to a storage area.
2. Do not sign a delivery receipt or a freight bill until you have made a proper count and inspection of all merchandise received.
3. Note all damage to packages directly on the carrier's delivery receipt.
4. Make certain the driver signs this receipt. If he refuses to sign, make a notation of this refusal on the receipt.
5. If the driver refuses to allow inspection, write the following on the delivery receipt:

Driver refuses to allow inspection of containers for visible damage.

6. Telephone the carrier's office immediately upon finding damage, and request an inspection. Mail a written confirmation of the time, date, and the person called.
7. Save any packages and packing material for further inspection by the carrier.
8. Promptly file a written claim with the carrier and attach copies of all supporting paperwork.

We will continue our policy of assisting our customers in collecting claims which have been properly filed and actively pursued. We cannot, however, file any damage claims for you, assume the responsibility of any claims, or accept deductions in payment for such claims.

RECORD THE MODEL AND SERIAL NUMBER OF THE APPLIANCE FOR EASY REFERENCE. ALWAYS REFER TO BOTH MODEL AND SERIAL NUMBER IN ANY CONTACT WITH ALTO-SHAAM REGARDING THIS APPLIANCE.

Model: _____

Serial Number: _____

Date Installed: _____

Voltage: _____

Purchased From: _____



Alto-Shaam has established a twenty-four hour emergency service call center to offer immediate customer access to a local authorized service agency outside of standard business hours. The emergency service access is provided exclusively for Alto-Shaam equipment and is available throughout the United States through the use of Alto-Shaam's toll-free number. Emergency service access is available seven days a week including holidays.