

## MODEL VFB12 COUNTER ELECTRIC FLASHBAKE® OVEN



### STANDARD FEATURES

- Stainless steel front, sides and top.
- Stainless steel door with window.
- 4" legs.
- Alanod oven interior measures 18"w x 18"d x 7<sup>3</sup>/<sub>4</sub>"h.
- 16" diameter carousel cooking grill.
- Seven 2,000 watt quartz halogen lamps, four on the top and three on the bottom. No pre-heat time required.
- Electronic digital controls accept 10 recipe programs.
- 208 or 240 volt, 60 Hz, 1 or 3 phase. 11.9 KW maximum draw.
- One year limited parts and labor warranty.

### OPTIONS

- 72" cord and plug.
- Second year extended limited parts and labor warranty.

### ACCESSORIES

- 16" diameter grill.
- 12" diameter silverstone non-stick pan.
- 6", 7", 10", 12", 14" and 16" diameter black pans for fresh dough pizzas.
- 12" diameter Flashware cooking dish.



ANSI/NSF Standard #4



### SPECIFICATIONS:

Counter electric FlashBake® Oven, Vulcan Model No. VFB12. Front, sides, top and oven door constructed of 304 series stainless steel. Observation window is #5 welders glass. Reflective Alanod oven interior measures 18"w x 18"d x 7<sup>3</sup>/<sub>4</sub>"h. 16" diameter carousel cooking grill. Seven 2,000 watt quartz halogen lamps, four on the top and three on the bottom. No pre-heat time required. Electronic digital controls accept 10 recipe programs. 208 or 240 volt, 60 Hz, 1 or 3 phase.

Exterior dimensions: 27<sup>3</sup>/<sub>8</sub>"w x 28<sup>7</sup>/<sub>8</sub>"d x 19<sup>1</sup>/<sub>2</sub>"h on 4" legs.

Classified by U L to NSF Std. #4. U L listed. U L listed to Canadian safety standards.



# MODEL VFB12

## COUNTER ELECTRIC FLASHBAKE® OVEN

### IMPORTANT

1. This appliance must be installed with 6" clearance at both sides and 1" clearance at the rear adjacent to both combustible and non-combustible construction.
2. This appliance is manufactured for commercial installation only and is not intended for domestic/household installation.

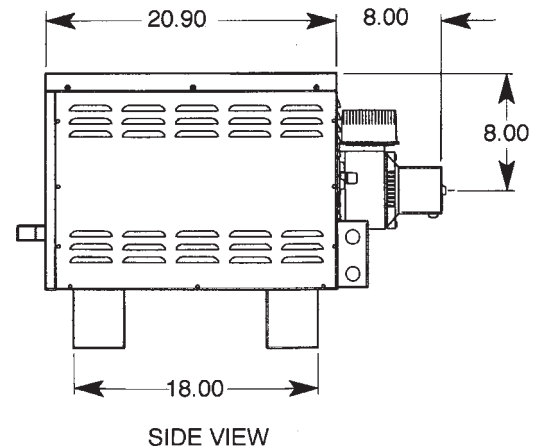
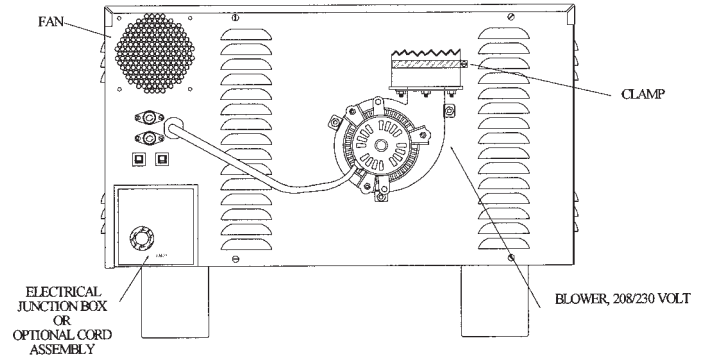
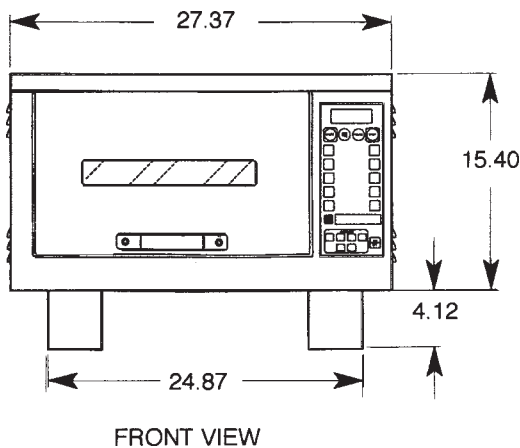
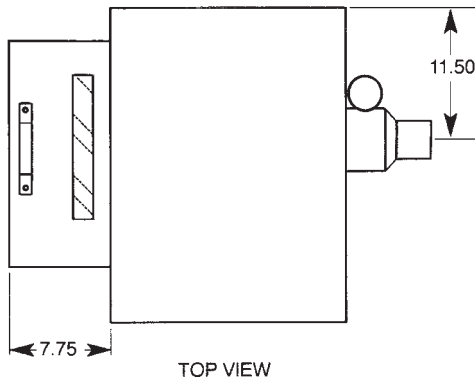

### PHYSICAL SPECIFICATIONS

Length	Depth	Height	Weight	Ship Wt.	Ship Size	Construction	Cooking Cavity	Cooking Surface
27 <sup>3</sup> / <sub>8</sub> "	28 <sup>7</sup> / <sub>8</sub> "	19 <sup>1</sup> / <sub>2</sub> "	100 lbs.	150 lbs.	34.5" x 33" x 28" = 18.45 sq. ft.	Stainless Steel	18" x 18" x 7 <sup>3</sup> / <sub>4</sub> "	16" diameter

### ELECTRICAL SPECIFICATIONS

Model <sup>1</sup>	Voltage			Maximum		Typical		Breaker Size	NEMA Receptacle
	Phase	Cycles	Power	Current	Power	Current			
VFB12	208/240	1	60	11.9 KW	56 A	9 KW	43 A	60 A	14-60R
	208/240	3	60	11.9 KW	35 A	9 KW	27 A	40A <sup>2</sup>	15-50R

1 Plug and cord optional, for additional cost.

2 50A if cord connected.

**NOTE:** In line with its policy to continually improve its products, Vulcan-Hart Company reserves the right to change materials and specifications without notice.