

REFRIGERATOR MANUFACTURER
Turbo air
 more durable, convenient, beautiful

1250 Victoria St
 Carson, CA 90746
 Tel. 310-900-1000
 Fax. 310-900-1077
www.turboairinc.com

Project :	
Model # :	
Item # :	Qty :
Available W/H :	
Approval :	

Undercounter Refrigerator

Undercounters
 Super Deluxe Series

Model : TUR-28SD*

**EXCEPTIONAL 3 YEAR
 PARTS & LABOR WARRANTY**



FEATURES / BENEFITS

■ STAINLESS STEEL CABINET CONSTRUCTION

The Turbo Air Super Deluxe model boasts a stainless steel interior and exterior (galvanized steel back & bottom). It guarantees the utmost in cleanliness and long product life. The Super Deluxe can add a touch of style to the most refined setting.

■ STURDY, CLEAN STAINLESS SHELVING

Shelves are the most important part of cleanliness as they come in direct contact with food. After a while, PVC coated wire shelves may peel, rust and lead to unsanitary conditions. Only the Turbo Air Super Deluxe series uniquely provides stainless shelving.

■ HOT GAS CONDENSATE SYSTEM

Through Turbo Air's creative innovation, the condensate system surfaces have been specially treated to resist corrosion. This not only increases efficiency without the risk of refrigerant leakage from corrosion, but also prevents the overflow of condensate water.

■ EFFICIENT REFRIGERATION SYSTEM

Turbo Air's solid door refrigerators are designed with oversized and balanced (CFC Free R-134A) refrigeration systems. These include efficient evaporators and condensers for faster cooling and greater efficiency.

■ HIGH-DENSITY POLYURETHANE INSULATION

The entire cabinet structure and solid doors are foamed-in-place using high density, CFC free polyurethane insulation.

■ ERGONOMICALLY DESIGNED DOORS

Customers' fatigue fades away with easy grip handles and doors that open effortlessly. These features along with self-closing doors make this the ultimate choice in customer convenience. ABS sheet door liners resist water condensation with thermal efficiency.

■ MAGNETIC DOOR GASKETS

Magnetic door gaskets are of one piece construction, removable without tools for ease of cleaning and replacement.

■ REFRIGERATOR HOLDS 33°F ~ 38°F FOR THE BEST IN FOOD PRESERVATION



ENERGY STAR®
 Qualified

Model	Swing Door	CU./FT.	#of Shelves	HP	AMPS	Crated Weight (lbs.)	L x D [*] x H [†] (inches)
TUR-28SD*	1	7	1	1/4	6.6	163	27 1/2 x 30 x 30 5/8

Undercounter Refrigerator

Undercounters
Super Deluxe Series

Model : TUR-28SD*

ELECTRICAL DATA	
Voltage	115/60/1
Plug Type	Ⓜ NEMA-5-15P
Full Load Amperes	6.6
Compressor HP	1/4
Cord Length ft.	9
Refrigerant	R-134A
DIMENSIONAL DATA	
Net Capacity cu. ft.	7
Ext. Length Overall in.	27 1/2 (699mm)
Ext. Depth Overall in.*	30 (762mm)
Ext. Height Overall in.†	30 5/8 (777mm)
# of Doors	1
# of Shelves	1
Gross Weight lbs.	163
Net Weight lbs.	146

Design and specifications subject to change without notice.
Actual shipping weight may differ due to extra packing materials for product protection.

*Depth does not include 1" for rear spacers.

† Height does not include 5-7/8" for caster height.

- **WARRANTY :** Exceptional 3 Year Parts and Labor Warranty
Additional 2 Year Warranty on Compressor

- **SELF-CONTAINED SYSTEM**

- **4" SWIVEL CASTERS**

OPTIONAL ACCESSORIES :

- 2.5" Diameter casters
- 5" Diameter casters
- 6" ABS plastic legs
- Additional stainless steel shelves
- Additional PE coated wire shelves

PLAN VIEW

(unit : inch)

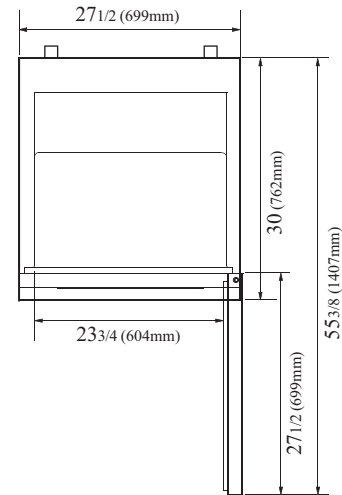

PLAN VIEW

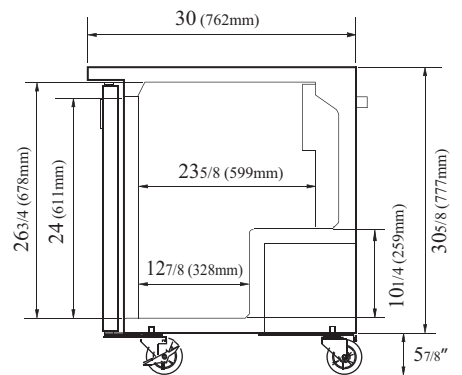

SIDE VIEW

Ver.201301



ENERGY STAR®
Qualified

- Turbo Air : 800-627-0032
- GK : 800-500-3519
- Warranty : 800-381-7770
- AC : 888-900-1002

