

**TURBO AIR** REFRIGERATOR MANUFACTURER  
**Turbo air**  
 more durable, convenient, beautiful

1250 Victoria St  
 Carson, CA 90746  
 Tel. 310-900-1000  
 Fax. 310-900-1077  
[www.turboairinc.com](http://www.turboairinc.com)

Project :	
Model # :	
Item # :	Qty :
Available W/H :	
Approval :	

**Ice Cream Freezer** Ice Cream Freezers  
Horizontal Freezers

**Model : TGF-9F**



**FEATURES / BENEFITS**

- **ENVIRONMENTALLY FRIENDLY, EFFICIENT REFRIGERATION SYSTEM**  
 Turbo Air's freezers are designed with oversized and balanced environmentally friendly R-404A (CFC Free) refrigeration system. These include large evaporators and condensers for faster freezing and greater efficiency throughout the cabinet.
- **TEMPERED, ENERGY SAVING LOW EMISSIVITY GLASS SLIDING TOP**  
 Reduced outer heat gain and lowers energy consumption. It enhances energy efficiency and minimizes condensation.
- **ADVERTISING PANEL AND ATTRACTIVE GLASS LIDS**  
 Optimize eye-catching display and impulse sales. Economical size and design for convenient access and fast service in high traffic area.
- **HIGH-DENSITY POLYURETHANE INSULATION**  
 The entire cabinet structure is foamed-in-place using high density, CFC free polyurethane insulation.
- **EASY TEMPERATURE CONTROL MODE IS ENERGY EFFICIENT**  
 There is no need to reach inside the freezer to control the temperature. External temperature control knob allows easy adjustment and keeps cold air inside saving energy.
- **FREEZER HOLDS -9°F ~ 11°F FOR THE BEST IN FROZEN FOOD PRESERVATION**
- **MANUAL DEFROST SYSTEM**
- **HEAVY DUTY WHITE PE (POLYETHYLENE) COATED DIVIDERS COME STANDARD**
- **WHITE, ANTI-RUST COATING ON THE EXTERIOR REDUCES FINGERPRINTS**



Model	Sliding Door	CU./FT.	Baskets	HP	AMPS	Crated Weight (lbs.)	L x D x H* (inches)
<b>TGF-9F</b>	<b>1</b>	<b>8.5</b>	<b>-</b>	<b>1/4</b>	<b>4.4</b>	<b>195</b>	<b>44 1/4 x 27 3/8 x 35 3/8</b>

Ver.201203

\* Height does not include 4" for caster height.

## Model : TGF-9F

ELECTRICAL DATA	
Voltage	115/60/1
Plug Type	ⓘ NEMA-5-15P
Full Load Amperes	4.4
Compressor HP	1/4
Cord Length ft.	8
Refrigerant	R-404A
DIMENSIONAL DATA	
# of Doors	1
Net Capacity cu. ft.	8.5
Ext. Length Overall in.	44 1/4 (1124mm)
Ext. Depth Overall in.	27 3/8 (696mm)
Ext. Height Overall in.*	35 3/8 (899mm)
Int. Length Overall in.	39 1/4 (997mm)
Int. Depth Overall in.	21 3/4 (552mm)
Int. Height Overall in.	16 5/8 (423mm)
Gross Weight lbs.	195
Net Weight lbs.	185
# of Baskets	-
Net Capacity Gal.	63.6

Design and specifications subject to change without notice.  
Actual shipping weight may differ due to extra packing materials for product protection.  
\* Height does not include 4" for caster height.

- **WARRANTY : 1 Year Parts and Labor Warranty**  
Additional 4 Year Warranty on Compressor
- **NO PLUMBING REQUIRES**
- **SELF-CONTAINED SYSTEM**
- **2.5" DIA. CASTERS STANDARD (TGF MODELS)**

## PLAN VIEW

(unit : inch)

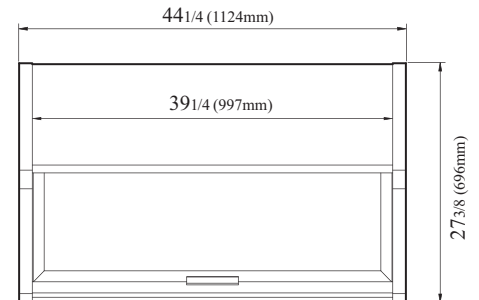

PLAN VIEW

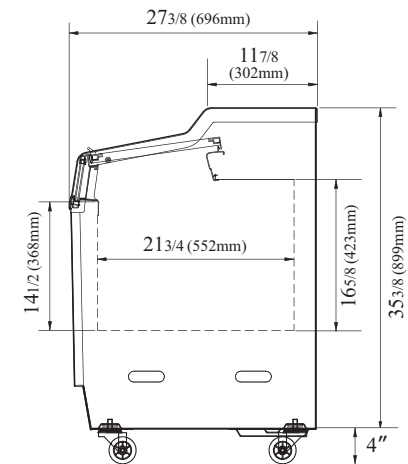

SIDE VIEW

Ver.201203



- Turbo Air : 800-627-0032
- GK : 800-500-3519
- Warranty : 800-381-7770
- AC : 888-900-1002