

REFRIGERATOR MANUFACTURER
Turbo air
 more durable, convenient, beautiful

1250 Victoria St
 Carson, CA 90746
 Tel. 310-900-1000
 Fax. 310-900-1077
 www.turboairinc.com

Project :	
Model # :	
Item # :	Qty :
Available W/H :	
Approval :	

Clup Top Beer Dispenser

Underbar Equipment
 Clup Top Beer Dispensers

**EXCEPTIONAL 3 YEAR
 PARTS & LABOR WARRANTY**

Model : TCB-4SD/SB



TCB-4SD



TCB-4SB

- Does not include keg couplers
 - 2 Year Parts and Labor Warranty for SB Unit

FEATURES / BENEFITS

EFFICIENT REFRIGERATION SYSTEM

Turbo Air's refrigerators are designed with oversized and balanced R-134A (CFC Free) refrigeration systems. These include efficient evaporators and condensers for faster cooling and greater efficiency.

FORCED AIR COOLING SYSTEM

Fast cooling and balanced temperature throughout the cabinet.

STAINLESS STEEL CABINET CONSTRUCTION

Super Deluxe (SD) models boast a stainless steel exterior (except galvanized steel back and bottom). SB models are attractive wear-resistant black vinyl exterior. Heavy gauge stainless steel countertop and club top lids are perfect for sanitation and durability. Interior is stainless steel floor and door liners with white painted galvanized steel inside walls. Turbo Air Club Top model guarantees utmost in cleanliness and long product life. It also can add a touch of style to the most refined setting.

HIGH-DENSITY POLYURETHANE INSULATION

The entire cabinet structure is foamed-in-place using high density, CFC free polyurethane insulation.

3" DIAMETER STAINLESS STEEL INSULATED BEER COLUMNS

EASY ACCESS TO THE INTERIOR AREA

Club Top is a combined functional cabinet of direct draw cold beer dispenser and glass chiller. This convenient model provides easy access to interior storage area of the refrigerator for chilled beer glasses.

EASY TO GLIDE STAINLESS STEEL CLUB TOP LIDS

ERGONOMICALLY DESIGNED DOORS

Customers' fatigue fades away with easy grip handles and doors that open effortlessly. These features along with self-closing doors make this the ultimate choice in customer convenience.

SIDE MOUNT COMPRESSOR UNIT

Through positioning the compressor to the side, the refrigerator can be serviced without being moved. By innovatively creating a **front breathing** feature, this model can provide high efficiency in narrow spaces.

REFRIGERATOR HOLDS 33°F ~ 38°F FOR THE BEST IN BEVERAGE PRESERVATION



Model	Swing Door	1/2 Barrels	HP	AMPS	Crated Weight (lbs.)	L x D* x H† (inches)
TCB-4SD	3	4	1/3	7.5	445	90 3/8 x 27 1/4 x 38 5/8
TCB-4SB	3	4	1/3	7.5	445	90 3/8 x 27 1/4 x 38 5/8

Clup Top Beer Dispenser

Underbar Equipment
Clup Top Beer Dispensers

Model : TCB-4SD/SB

ELECTRICAL DATA	
Voltage	115/60/1
Plug Type	ⓘ NEMA-5-15P
Full Load Amperes	7.5
Compressor HP	1/3
Refrigerant	R-134A
Cord Length (ft.)	9
DIMENSIONAL DATA	
Cubic feet (1/2 Barrels)	4
Ext. Length Overall in.	90 ³ / ₈ (2296mm)
Ext. Depth Overall in. †	27 ¹ / ₄ (692mm)
Ext. Height Overall in.	38 ⁵ / ₈ (980mm)
Gross Weight lbs.	445
Net Weight lbs.	425
# of Swing Door	3

Design and specifications subject to change without notice.
Actual shipping weight may differ due to extra packing materials for product protection.
* Depth does not include 2" for rear spacers.
† Height does not include 5" for caster height. Height does not include 15-1/8" for draft arm.

- **WARRANTY : 3 Year Parts and Labor Warranty**
(SD Model) **Additional 2 Year Warranty on Compressor**
- **WARRANTY : 2 Year Parts and Labor Warranty**
(SB Model) **Additional 3 Year Warranty on Compressor**
- **SELF-CONTAINED SYSTEM**
- **4" SWIVEL CASTERS STANDARD**
- **2 FAUCETS BEER COLUMNS AVAILABLE (OPTIONAL)**
- **DOOR LOCKS STANDARD**

PLAN VIEW

(unit : inch)

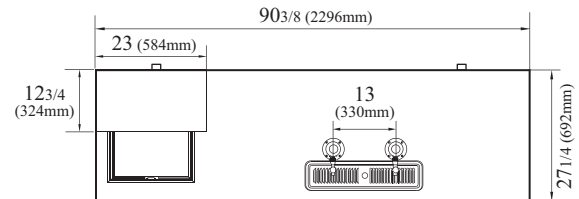

PLAN VIEW

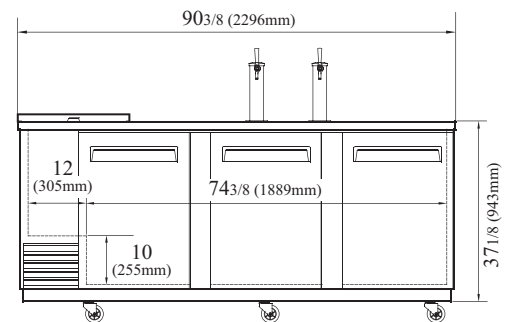

FRONT VIEW

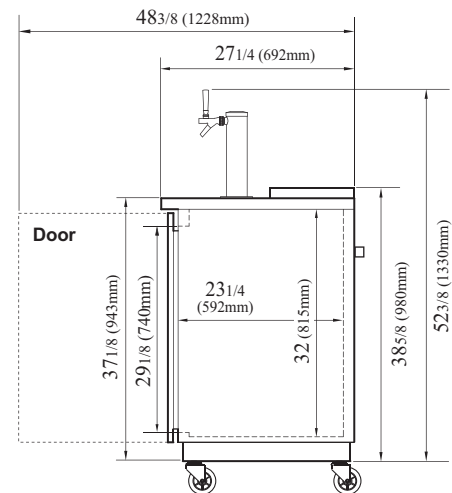

SIDE VIEW

Ver.201301



- Turbo Air : 800-627-0032
- GK : 800-500-3519
- Warranty : 800-381-7770
- AC : 888-900-1002

